



**NOTICE OF REGULAR MEETING**  
**Park Board of Trustees of the City of Galveston**  
**Finance and Operations Committee**  
**Tuesday, January 10, 2023, 1:30 p.m.**  
**Park Board Plaza Board Room - 1st Floor**  
**601 Tremont**  
**Galveston, Texas 77550**

- I. Call Meeting To Order
- II. Pledge Of Allegiance
- III. Roll Call And Declaration Of A Quorum
- IV. Conflict Of Interest Declarations
- V. Requests To Address The Committee  
*The public shall be allowed to provide comment to the committee regarding one or more agenda or non-agenda items. All requests to address the committee must be submitted in writing and can be presented to the committee reporter the day of the meeting or by completing the Public Comment Form available on the Park Board of Trustees website at the following link prior to the start of the meeting:*  
[HTTPS://WWW.GALVESTONPARKBOARD.ORG/FORMS.ASPX?FID=65.](https://www.galvestonparkboard.org/forms.aspx?fid=65)
- VI. Discuss And Consider Approval Of November 8, 2022 Meeting Minutes  
  
Documents:  
  
[DRAFT 11-8-2022 FOC MEETING MINUTES.PDF](#)
- VII. Discuss And Consider Approval For Bus Stop Lighting Repair At Urban Park (Vincent Loreface, 5 Minutes)  
  
Documents:  
  
[BUS STOP LIGHTING OVERVIEW.PDF](#)  
[BUS STOP BID TAB.PDF](#)
- VIII. Discuss And Consider Approval Of Lease Agreement With Visual Edge IT For Park Board Plaza Printer/Copier Machines (Schel Heydenburg, 5 Minutes)  
  
Documents:  
  
[PRINTER-COPIER EQUIPMENT LEASE AGREEMENT.PDF](#)
- IX. Discuss And Consider Approval To Award Contract To Vanguard Truck Centers Of Houston For Visit Galveston Box Truck With Lift Gate (Jacquelyn Helton, 5 Minutes)

Documents:

[VANGUARD TRUCK.PDF](#)

- X. Discuss And Consider Approval Of Scope Of Work And Process For 3rd Party Cash Balance Audit (Bryson Frazier, 15 Minutes)
- XI. Discuss And Review City Auditor's Request To Schedule A Follow-Up Audit On The Park Board's Procurement Procedures (Bryson Frazier, 5 Minutes)

Documents:

[CMS-PROCUREMENT AUDIT.PDF](#)

- XII. Discuss And Consider Approval Of Fiscal Year 2022 September Unaudited Financial Statements (Bryson Frazier, 15 Minutes)

Documents:

[SEPTEMBER 2022 UNAUDITED FINANCIAL STATEMENTS.PDF](#)

- XIII. 2022-2023 Committee Work Plan

Documents:

[FOC FY22-23 WORKPLAN.PDF](#)

- XIV. Future Agenda Items
- XV. Announcements
- XVI. Adjournment

***I certify that the above Notice of Meeting was posted in a place convenient to the public, in accordance with Chapter 551 of the Texas government Code, on or before January 6, 2023, 5:00 p.m.***

**Approved**

Dave Jacoby, Chair, FOC

**Approved**

Marty Fluke, Chair, Park Board of Trustees

**Approved as to Format**

Kelly de Schaun, Chief Executive Officer

**Please Note Members of the City Council may be attending and participating in the discussion.**

In accordance with the provisions of the Americans with Disabilities Act (ADA), persons in need of a special accommodation to participate in this proceeding shall, within three (3) days prior to any proceeding, contact the Park Board Administration

Office, 601 Tremont, Galveston Texas 77550 (409-797-5147)



**Park Board of Trustees of the City of Galveston  
Finance and Operations Committee**

11/8/2022 - Minutes

I. Call Meeting To Order

The meeting was called to order at 1:31 p.m.

II. Pledge Of Allegiance

The pledge was recited by those present.

III. Roll Call And Declaration Of A Quorum

Roll was called and a quorum declared.

Committee members present: Dave Jacoby, Jason Hardcastle, Jeff Ossenkop and Spencer Priest.

IV. Conflict Of Interest Declarations

There were no conflicts to declare.

V. Requests To Address The Committee

Charlotte O'Rourke addressed the committee on the financial statements.

VI. Discuss And Consider Approval Of Meeting Minutes

**Motion:** Jason Hardcastle motioned to approve the September 13, 2022 Committee meeting minutes.

**Second:** Spencer Priest seconded.

**Vote:** Approved (4-0).

VII. Discuss And Consider The Approval Of A Professional Services Agreement With Atkins For General Regulatory Agency Matters For FY 22-23 (Bryson Frazier, 5 Minutes)

Bryson Frazier reviewed the request to enter into an agreement with Atkins for regulatory consulting services and that the cost would not exceed \$20,000.

**Motion:** Spencer Priest motioned to approve the Professional Services Agreement with Atkins for General Regulatory Services.

**Second:** Jason Hardcastle seconded.

**Vote:** Approved (4-0).

VIII. Discuss And Consider Approval For Planter Box Landscaping Work At Urban Park (Corey Holcomb, 5 Minutes)

Corey Holcomb shared that the landscaping project for the planter boxes would include replacement of the irrigation systems and topsoil. He reported that this would be phase 1 for these boxes and will bring back phase 2

which will be for the planting of floral. Mr. Holcomb reported that there were three bids and staff is recommending to accept the one from Beach Town Lawn Service in the amount of \$14,500.

**Motion:** Jason Hardcastle motioned to approve the proposal from Beach Town Lawn Service for the phase 1 landscaping of the planter boxes in Urban Park.

**Second:** Jeff Ossenkop seconded.

**Vote:** Approved (4-0).

IX. Discuss And Consider Approval To Purchase A Club Car Carryall 500 For Seawolf Park (Corey Holcomb, 5 Minutes)

Corey Holcomb reported that Seawolf Park currently has three golf carts used in the daily operations of the park and that the budget was set to replace two of them due to their age and condition. He shared that the request today is for a utility cart that could be outfitted to offer concessions such as snacks, bait, etc. since there are no concession services currently offered at the park. Mr. Holcomb asked for approval to purchase this cart through the Sourcewell purchasing coop in the amount of \$12,483.06. In addition, he requested approval to trade in or auction the older cart and to use these funds towards the purchase of a regular golf cart which would fall under the amount required for Board approval.

**Motion:** Spencer Priest motioned to approve the purchase of the utility cart and to auction or trade in the older cart towards funding the purchase of the regular golf cart. .

**Second:** Jason Hardcastle seconded.

**Vote:** Approved (4-0).

X. Discuss And Consider Approval Of Electrical Upgrades At East Beach (Vince Lorefice, 5 Minutes)

Vince Lorefice reviewed the recently approved enhancements to entrance gate off of R.A. Apffel road at the East Beach. He shared that this would require the extension of the main electricity system to this area. Mr. Lorefice asked for approval of \$18,000 for Centerpoint Electric to extend the mainline to the entrance and \$18,231.01 for Crescent Electric to coordinate this extension and install the meter, and electrical components needed to complete this project.

**Motion:** Dave Jacoby motioned to approve the requested expenditures for Centerpoint and Crescent Electric for the electrical upgrades at East Beach.

**Second:** Jeff Ossenkop seconded.

**Vote:** Approved (4-0).

XI. Discuss And Consider Approval To Award Contract To Immaculate Painting For Dellanera RV Park Pavilion Exterior Painting (Tim Jackson, 5 Minutes)

Vince Lorefice shared that the exterior of the pavilion at Dellanera is in need of painting. He reported that bids were solicited and that staff is recommending to award the contract to Immaculate Painting in the amount of \$15,787.25.

**Motion:** Jason Hardcastle motioned to approve awarding the contract for painting the pavilion to Immaculate Painting.

**Second:** Spencer Priest seconded.

**Vote:** Approved (4-0).

XII. Discuss And Consider Approval To Purchase Sealver PRO WB 575 Rescue Craft (Peter Davis, 5 Minutes)

Peter Davis reported that the requested rescue craft would replace an unreliable boat frequently out for repairs. He shared that this couples with a jet ski as the motor which would improve the reliability since Beach Patrol has several jet skis. Chief Davis also shared that the old boat would be auctioned with the funds helping to defray the

cost of this purchase. He asked for approval to proceed with the purchase of the Sealver Pro Rescue Craft in the amount of \$37,575 plus shipping.

**Motion:** Jason Hardcastle motioned to approve the purchase of the Sealver Pro rescue craft.

**Second:** Jeff Ossenkop seconded.

**Vote:** Approved (4-0).

XIII. Discuss And Consider Approval Of Rates For Concessionaire Use Of Amenities And Utilities (Ann Hobing, 5 Minutes)

Ann Hobing reviewed the updated information that was requested at the September meeting which included the the additional market rate information for assistance in comparing the scenarios and alignment to cover costs. She shared that Bryson Frazier contacted some local realtors to gather data and reported that the average commercial cost per square foot is averaging between \$1.48 and \$1.59. Ms. Hobing stated that staff is recommending scenario 3 at \$1.50 per square foot along with the utilities proposal updated based on use.

**Motion:** Jeff Ossenkop motioned to approve the staff recommendation of scenario 3 and the utility fees proposed.

**Second:** Spencer Priest seconded.

**Vote:** Approved (4-0).

XIV. Discuss And Review Vehicle Needs Assessment (Bryson Frazier, 10 Minutes)

Bryson Frazier reported that the supply chain for vehicles is still feeling the impacts from the pandemic in efforts to fulfill government orders. He reviewed the list of needed vehicles for Coastal Zone Management, Beach Patrol and the parks and shared several possible solutions. Mr. Frazier would like to continue to work with Enterprise Fleet Management on the sourcing of the vehicles and bring these back for approval before finalizing the lease and/or purchase. The committee was supportive of this recommendation.

XV. Discuss And Consider Approval Of Renewal Of Credit Line And The Certificate Of Deposit At Moody National Bank (Bryson Frazier, 5 Minutes)

Bryson Frazier reported that the Park Board holds a line of credit in the amount of \$540,000 secured by a certificate of deposit, at Moody National Bank. The interest rate on this line is 1.95% and used to finance equipment purchases and other expenses as needed. Mr. Frazier is seeking approval to review this credit and certificate of deposit.

**Motion:** Dave Jacoby motioned to approve the renewals as requested.

**Second:** Spencer Priest seconded.

**Vote:** Approved (4-0).

XVI. Discuss And Consider Approval Of The Park Board Investment Policy And Authorize Publication Of A Request For Proposals For Investment Services (Bryson Frazier, 15 Minutes)

Bryson Frazier reported that the City of Galveston's investment policy was used as a template in the creation of the proposed Park Board investment policy being presented for approval. Mr. Frazier reviewed the policy. He also shared that once the policy is approved by the Board, staff is also seeking authority to develop and publish a request for proposals (RFP) for investment services.

**Motion:** Spencer Priest motioned to approve the investment policy and authorize the request for proposal for investment services.

**Second:** Jeff Ossenkop seconded.

**Vote:** Approved (4-0).

XVII. Discuss And Consider Approval Of Fiscal Year 2022 July And August Unaudited Financial Statements (Bryson Frazier, 15 Minutes)

Bryson Frazier reviewed the financial statements.

**Motion:** Spencer Priest motioned to approve the FY 2022 July and August unaudited financial statements.

**Second:** Jason Hardcastle seconded.

**Vote:** Approved (4-0).

XVIII. Executive Session

The meeting entered into executive session at 2:38 p.m.

A. Pursuant To Texas Local Government Code Section 551.074 - Personnel Matters - To Deliberate The Appointment, Employment, Evaluation, Reassignment Or Duties Of A Public Officer Or Employee

XIX. Action Item(S) Resulting From Executive Session

The open meet resumed at 3:29 p.m.

A. Discuss And Consider Action For Any Executive Session Item Listed On The Meeting Agenda

No action was taken.

XX. 2022-2023 Committee Work Plan

No changes at this time.

XXI. Future Agenda Items

Review of all liabilities, rates, terms, etc.

XXII. Announcements

Dellanera Beach Nourishment Project is scheduled to begin at the end of the week.

XXIII. Adjournment

The meeting was adjourned at 3:31 p.m.



**Agenda Item:** Discuss And Consider Approval For Bus Stop Lighting Repair At Urban Park

**Background:**

Over the years lighting components in the bus stops along the Seawall have become inoperative. Staff consulted with an electrician to determine the most cost-efficient repairs. The price noted below is a “worst-case” “not to exceed” scenario, the electrician will troubleshoot each bus stop to determine the minimal repairs needed to make the lights operational.

Scope of work: as needed

- Controllor Replacement
- Batteries Replacement
- LED Light Replacement

**Staff Recommendation:**

Staff recommends awarding contract to Crescent Electric utilizing Buy Board contract # 638-21 for bus stop lighting repair at Urban Park with a not to exceed amount of \$31,033.24.

**Funding Source (if applicable):**

UP-51-5240 – M&R.





**Agenda Item:** Discuss and Consider Approval of Lease Agreement with Visual Edge IT for Park Board Plaza Printer/Copier Machines

**Background:** In August 2020, the Park Board entered into a lease agreement with Visual Edge for two printer/copiers for the main office. This agreement is scheduled to expire in 2025. These machines have begun to experience frequent mechanical failures. Visual Edge has offered to replace these with two new machines at the same monthly rental rate of \$1,908.00. In addition, they are also offering a reduction in overage charges from the current B/W rate of .0098 to .0061 and Color rate of .049 to .042 contingent on a new 63 month agreement.

**Staff Recommendation:** Staff is recommending entering into the new agreement with Visual Edge IT for replacement of the current printer/copiers and the lower copy overage rate.

**Funding Source (if applicable):**  
GF50-5130 and TD70-5130



---

**Agenda Item:** Discuss And Consider Approval to Award Contract To Vanguard Truck Centers of Houston for Visit Galveston Box Truck with Lift Gate

**Background:** As part of the Approved Fiscal Year 2023 Tourism Development Budget, funds were allocated for a Box Truck with Lift Gate. Visit Galveston activated a sealed Request for Proposals for a qualified vendor to provide a cargo box with lift gate that meets certain specifications, in order to greatly reduce the cost to transfer, ship, and distribute owned experiential assets as well as local distribution of Island Soul.

During 2022, Visit Galveston spent \$24,456.96 in freight and moving fees, and box truck rental charges to accommodate asset distribution for special events. The same year, Visit Galveston hired a part-time staff person to accommodate special-event activations and Island Soul distribution. That position soon became a full-time job because of the number of events and the volume of distribution work it required. The cost associated with moving the position from part-time to full-time was \$31,993. It has become clear that without additional transportation assets, the Visit Galveston team cannot increase the number of activations – and the additional revenue that comes with them. The purchase of a Box Truck will alleviate that problem. It will provide the opportunity to transport the Visit Galveston vending machine to special events, allow more experience activations and will facilitate Island Soul distributions without having to contract with an outside source. Visit Galveston would retain the full time staff person to manage distribution and assets, and would cover the purchase of the Box Truck within 2-3 years from rental savings and potential revenue.

Below were the specifications requested in the sealed bid process:

- GVWR: Can be Light Duty to Medium Duty
- Suspension: Spring (air, coil or leaf)
- Fuel Type: Unleaded or Diesel
- Transmission: Automatic 6-speed or similar
- Cab Type: Manufacturer standard
- Body Type: Cargo Box
- Cargo Box Length: Minimum 14'
- Cargo Box Width: Minimum 8'
- Lift Gate: Equipped with working lift gate
- Fuel Tank: Single, minimum 30-gallon capacity
- Tire size: manufacturer standard rated for truck, all weather
- Axles: Single
- Cab Features: AM/FM Radio, air conditioning and heat equipped, defrost
- Brakes: ABS
- Steering: Power
- Back-up Alarm: Required
- Windshield: Manufacturer standard with no cracks, working wipers equipped with blades
- Cruise Control
- Power Windows and Mirrors

- Tilt Wheel
- Box Must have illumination
- Roll Up Door Clearance: Minimum 8' in height
- Wall tie downs
- Solid floor that can hold at least 5,000 pounds
- Lift gate with vending stop and hydraulic operation

One proposal was received in the sealed process from Vanguard Truck Centers of Houston.

**Staff Recommendation:** Staff recommends awarding a contract to Vanguard Truck Centers of Houston for the Visit Galveston Box Truck with Lift Gate in the amount of \$78,230. pending approval from TDAC, Park Board of Trustees and approval and funding from the City of Galveston. \$80,000 was included in the FY2023 budget for this purchase as a Destination Experience Asset.

**Funding Source (if applicable):** TD70-7002, Destination Experience Assets





**New Vehicle Purchase Agreement**

VANGUARD TRUCK CENTER OF HOUSTON  
 12935 Crosby Fwy  
 Houston TX 77049  
 Phone: (281) 677-2200

DE-10000  
 PROS-018014  
 Nelson Calderon

**PROS-018014**  
**VISIT GALVESTON**  
 601 TREMONT ST.  
 GALVESTON TX 77550  
 P:(409) 797-5000

**VISIT GALVESTON**  
 601 TREMONT ST.  
 GALVESTON, TX 77550

Stock#: 1176796	VIN:54DB4W1D6PS206001	New 2023 Isuzu NPR	Price:	\$78,000.00
			<b>Total Price</b>	\$78,000.00
			Dealer Inventory Tax	\$230.72
			<b>Total</b>	<u>\$78,230.72</u>

PRICING NCLUDES 14' BOX WITH TUCK UNDER LIFGATE 2500LB CAPACITY.

**New Vehicle Purchase Agreement**

VANGUARD TRUCK CENTERS (the "COMPANY") SELLS THIS VEHICLE ON AN "AS IS WHERE IS" BASIS AND MAKES NO WARRANTIES AS TO SAID VEHICLE'S, EXPRESS, IMPLIED, OR IMPLIED BY LAW, AND COMPANY EXPRESSLY DISCLAIMS THE IMPLIED WARRANTY OF MERCHANTABILITY AND THE IMPLIED WARRANTY OF FITNESS FOR A PARTICULAR PURPOSE.

DATE ACCEPTED: \_\_\_\_\_ BY: \_\_\_\_\_

Email-nelson.calderon@vanguardtrucks.com

**Nelson Calderon**  
 SALES REPRESENTATIVE

SALES MANAGER

(PRINT NAME OF PURCHASER) **VISIT GALVESTON** (TITLE)  
 (BUSINESS NAME) (PHONE)  
**601 TREMONT ST.**  
 ADDRESS  
**GALVESTON TX 77550**  
 CITY, STATE, ZIP

<b>MODEL</b>	<b>NPR Gas</b>
<b>GVWR / GCWR</b>	12,000 lbs. / 18,000 lbs.
<b>WB</b>	109 in., 132.5 in., 150 in., 176 in.
<b>CA</b>	86.5 in., 110 in., 127.5 in., 153.5 in.
<b>ENGINE</b>	GMPT L8T (Gen V), 8-cylinder, V Block 4-cycle, OHV, Direct Fuel Injection, Oil Jet Piston Cooling
<b>MODEL/DISPLACEMENT</b>	GMPT-V8/400 CID (6.6 liters)
<b>HP (GROSS)</b>	350 HP @ 4500 RPM
<b>TORQUE (GROSS)</b>	425 lb.-ft. @ 3800 RPM
<b>EQUIPMENT</b>	Direct injection technology, mass air flow meter, powertrain interface module (PIM), onboard diagnostics, oxygen sensors, catalytic convertor, map sensor, with external oil cooler, engine cruise control, and rear engine cover.
<b>TRANSMISSION</b>	6L90 Hydra-Matic 6-speed automatic with lock-up converter and double overdrive. No PTO opening.
<b>STEERING</b>	Integral power steering 18.8-20.9:1 ratio. Tilt and telescoping steering column.
<b>FRONT AXLE</b>	Reverse Elliot "I" -beam rated at 6,830 lbs.
<b>FRONT SUSPENSION</b>	Semi-elliptical steel alloy tapered leaf springs with stabilizer bar and shock absorbers.
<b>FRONT GAWR</b>	4,860 lbs.
<b>REAR AXLE</b>	Full floating single speed with hypoid gearing rated at 14,550 lbs.
<b>REAR SUSPENSION</b>	Semi-elliptical steel alloy multi-leaf springs and shock absorbers.
<b>REAR GAWR</b>	8,840 lbs.
<b>WHEELS</b>	16 x 6.0 - 6 hole disc wheels, painted white.
<b>TIRES</b>	215/85R-16E (10 ply) LRR (Low Rolling Resistance) tubeless steel belted radials, all season front and rear
<b>BRAKES</b>	Dual circuit vacuum assisted hydraulic service brakes with EBD (Electronic Brake Distribution) system for load proportioning of the brake system front and rear disc brake. The parking brake is a mechanical, cable actuated, internal expanding drum type, transmission mounted. 4 channel anti-lock brake system.
<b>FUEL TANK</b>	38.6 gal. rectangular stainless steel fuel tank. Mounted between the frame rails with electric type fuel pump (mounted in tank) and fuel tank zone module (mounted on rearward crossmember). Through the rail fuel fill.
<b>FRAME</b>	Ladder type channel section straight frame rail 33.5 inches wide through the total length of the frame. Yield strength 44,000 psi, section modulus 7.20 in <sup>3</sup> , RBM 316,800 lb-in
<b>CAB</b>	All steel, low cab forward, BBC 70.9 in, 45° mechanical tilt with torsion assist.
<b>CAB EQUIPMENT</b>	TRICOT breathable cloth covered high back driver's seat with two occupant passenger seat. Dual cab mounted exterior mirrors with integral convex mirror. Tilt and telescoping steering column. Power windows and door locks, floor mats, tinted glass. AM/FM/CD Radio with Aux input/USB port and Bluetooth. Rear body dome lamp switch. Cab latch switch and indicator with buzzer. Bi-LED Head Lamps and Signature Light
<b>ELECTRICAL</b>	12 volt, negative ground, 750 CCA maintenance free battery located on frame, 170 Amp alternator with integral regulator.
<b>OPTIONS</b>	See last page for options.

**Note:** These selected specifications are subject to change without notice.

<b>MODEL</b>	<b>NPR-HD Gas</b>
<b>GVWR / GCWR</b>	14,500 lbs. / 20,500 lbs.
<b>WB</b>	109 in., 132.5 in., 150 in., 176 in.
<b>CA</b>	86.5 in., 110 in., 127.5 in., 153.5 in.
<b>ENGINE</b>	GMPT L8T (Gen V), 8-cylinder, V Block 4-cycle, OHV, Direct Fuel Injection, Oil Jet Piston Cooling
<b>MODEL/DISPLACEMENT</b>	GMPT-V8/400 CID (6.6 liters)
<b>HP (GROSS)</b>	350 HP @ 4500 RPM
<b>TORQUE (GROSS)</b>	425 lb.-ft. @ 3800 RPM
<b>EQUIPMENT</b>	Direct injection technology, mass air flow meter, powertrain interface module (PIM), onboard diagnostics, oxygen sensors, catalytic convertor, map sensor, with external oil cooler, engine cruise control, and rear engine cover.
<b>TRANSMISSION</b>	6L90 Hydra-Matic 6-speed automatic with lock-up converter and double overdrive. No PTO opening.
<b>STEERING</b>	Integral power steering 18.8-20.9:1 ratio. Tilt and telescoping steering column.
<b>FRONT AXLE</b>	Reverse Elliot "I" -beam rated at 6,830 lbs.
<b>FRONT SUSPENSION</b>	Semi-elliptical steel alloy tapered leaf springs with stabilizer bar and shock absorbers.
<b>FRONT GAWR</b>	6,630 lbs.
<b>REAR AXLE</b>	Full floating single speed with hypoid gearing rated at 14,550 lbs.
<b>REAR SUSPENSION</b>	Semi-elliptical steel alloy multi-leaf springs and shock absorbers.
<b>REAR GAWR</b>	11,020 lbs.
<b>WHEELS</b>	19.5 x 6.0 - 6 hole disc wheels, painted white.
<b>TIRES</b>	225/70R-19.5G (14 ply) LRR (Low Rolling Resistance) tubeless steel belted radials, all season front and rear
<b>BRAKES</b>	Dual circuit vacuum assisted hydraulic service brakes with EBD (Electronic Brake Distribution) system for load proportioning of the brake system front and rear disc brake. The parking brake is a mechanical, cable actuated, internal expanding drum type, transmission mounted. 4 channel anti-lock brake system.
<b>FUEL TANK</b>	38.6 gal. rectangular stainless steel fuel tank. Mounted between the frame rails with electric type fuel pump (mounted in tank) and fuel tank zone module (mounted on rearward crossmember). Through the rail fuel fill.
<b>FRAME</b>	Ladder type channel section straight frame rail 33.5 inches wide through the total length of the frame. Yield strength 44,000 psi, section modulus 7.20 in <sup>3</sup> , RBM 316,800 lb-in
<b>CAB</b>	All steel, low cab forward, BBC 70.9 in, 45° mechanical tilt with torsion assist.
<b>CAB EQUIPMENT</b>	TRICOT breathable cloth covered high back driver's seat with two occupant passenger seat. Dual cab mounted exterior mirrors with integral convex mirror. Tilt and telescoping steering column. Power windows and door locks, floor mats, tinted glass. AM/FM/CD Radio with Aux input/USB port and Bluetooth. Rear body dome lamp switch. Cab latch switch and indicator with buzzer. Bi-LED Head Lamps and Signature Light
<b>ELECTRICAL</b>	12 volt, negative ground, 750 CCA maintenance free battery located on frame, 170 Amp alternator with integral regulator.
<b>OPTIONS</b>	See last page for options.

**Note:** These selected specifications are subject to change without notice.

VEHICLE WEIGHTS AND DIMENSIONS

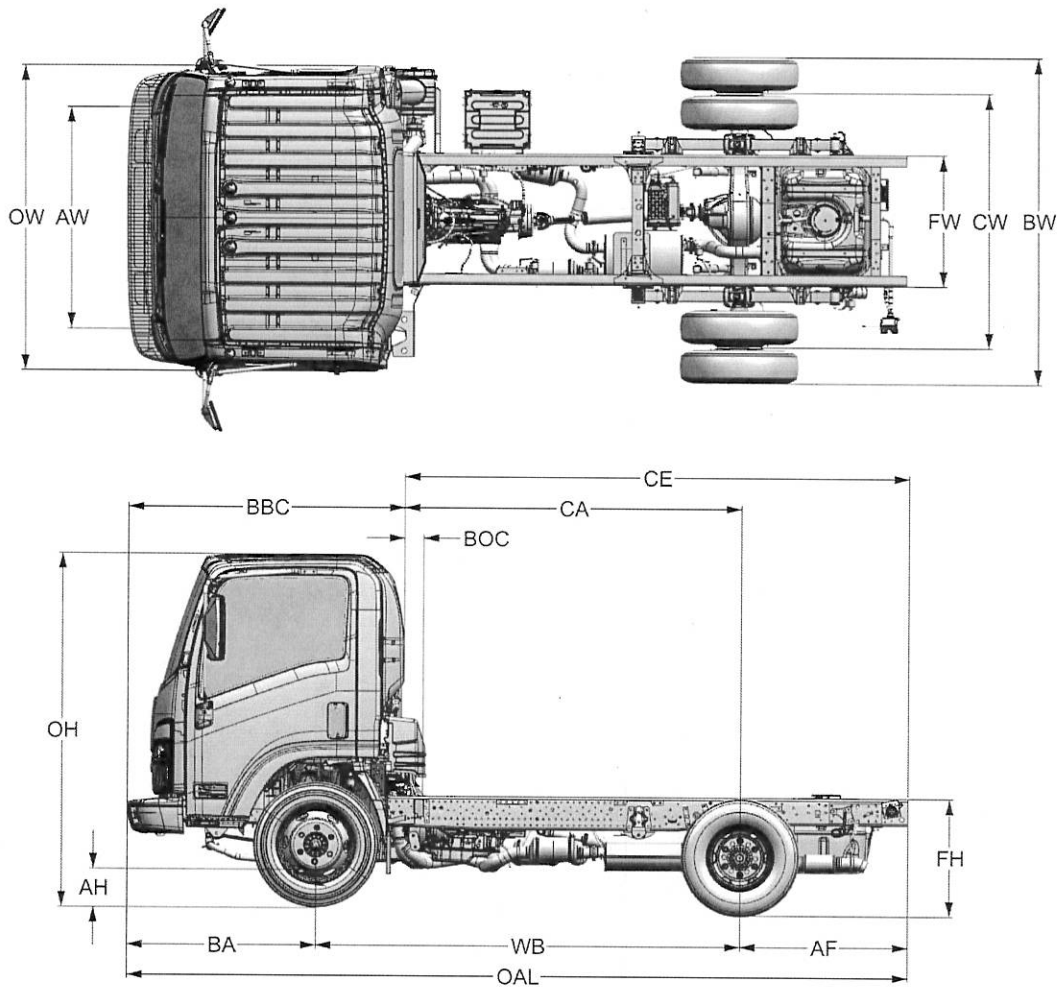

Figure 1: N-Series Gas Cab Chassis Dimensions

CHASSIS DIMENSIONS (in.)				
WB	CA <sup>[1]</sup>	CE <sup>[2]</sup>	AF	OAL
109	86.5	129.6	43.1	200.5
132.5	110.0	153.1	43.1	224.0
150	127.5	170.6	43.1	241.5
176	153.5	196.6	43.1	267.5
DIMENSION CONSTANTS (in.)				
AW = Front axle track				65.6
BA = Front bumper to centerline of axle				48.4
BBC = Bumper to back of cab				70.9
BOC = Back of cab clearance				7.7
BW = Overall width across rear axle				83.3
CW = Rear axle track				65
FW = Frame width				33.5
OW = Overall width across cab (without mirrors)				81.3
VARIABLE DIMENSIONS BY GVWR (in.)			12,000 lb.	14,500 lb.
AH = Ground to bottom of axle			7.5	8.3
FH = Frame height (unladen) at E.O.F. <sup>[3]</sup>			31.8	33
OH = Overall height (without clearance lights)			90	90.9

Chassis Curb Weights and Payloads						
NPR GAS - 12,000 lb. GVWR:						
Model	WB	Unit	Front	Rear	Total	Payload
1C1	109	lbs.	3348	1845	5193	6807
1C2	132.5	lbs.	3398	1895	5293	6707
1C3	150	lbs.	3418	1905	5323	6677
1C4	176	lbs.	3448	1925	5373	6627
NPR-HD GAS - 14,500 lb. GVWR:						
Model	WB	Unit	Front	Rear	Total	Payload
1F1	109	lbs.	3478	2075	5553	8947
1F2	132.5	lbs.	3528	2105	5633	8867
1F3	150	lbs.	3558	2115	5673	8827
1F4	176	lbs.	3588	2125	5713	8787

Notes: [1] Effective CA is CA less BOC.  
 [2] Effective CE is CE less BOC.  
 [3] Measured at the end of the frame from the top of the frame to the ground at curb weight.  
 [4] Chassis curb weight reflects standard equipment and fuel, but no driver or payload.  
 [5] Maximum Payload Weight is the allowed maximum for equipment, body, payload and driver and is calculated by subtracting chassis curb weight from the GVWR.

VEHICLE WEIGHT RATINGS		
Description	NPR Capacity (lb.)	NPR-HD Capacity (lb.)
GVWR Designed Maximum	12,000	14,500
GCWR Combined Maximum	18,000	20,500
GAWR – Front	4,860	6,630
GAWR – Rear	8,840	11,020

**Model Description**

The N-Series Gasoline vehicle features a low cab forward design that is ideally suited for intercity applications. The low cab design minimizes overall length for a given body length and in conjunction with the set back front axle positioning provides excellent weight distribution. The 49.5-degree (46.5 on 14,500lb GVWR) inside wheel cut angle coupled with integral power steering makes it an extremely maneuverable truck.

**Engine**

The N-Series Gasoline chassis is powered by a GMPT Gen V V8 gasoline engine with a displacement of 400 cubic inches (6.6 liters). This engine combines GM's Gen V aluminum head design with direct injection combustion technology to achieve a broader horsepower band and strong low-rpm torque. Oil-jet piston cooling channels are incorporated into the engine cast-iron cylinder block for optimized durability under heavy-duty use.

**Engine Data: GMPT-V8 w/50 State Certification**

Power:	350 HP @ 4500 RPM
Torque:	425 lb.-ft. @ 3800 RPM
Governed Speed:	4500 RPM
Injection:	Direct Fuel Injection
Displacement:	400 CID (6.6L)
Cylinder Bore:	103.25 mm
Cylinder Stroke:	98.0 mm
Cylinders:	8
Operating Cycles:	4-cycle
Compression:	10.8:1



Figure 2: GMPT Gen V V8 Engine

\*SAE J1349 Gross ratings without fan operating.

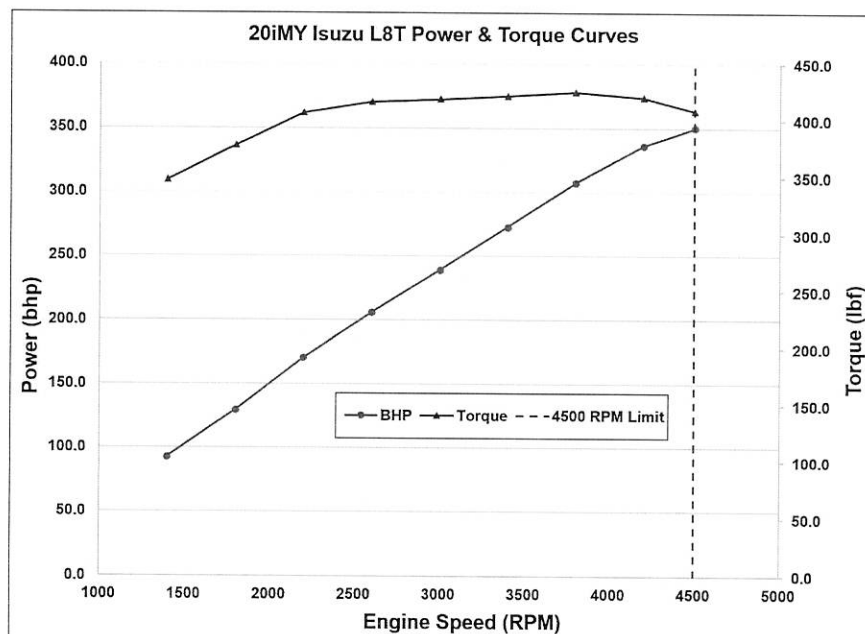

Figure 3: N-Series Gas Engine Performance Curve



---

**Agenda Item:** Discuss And Review City Auditor's Request To Schedule A Follow-Up Audit On The Park Board's Procurement Procedures

**Background:** In 2021, Park Board staff worked with the City Auditor's office to develop a Contract Management System and a Purchasing Policies, Procedures, and Controls Manual. In January 2023, the City Auditor's office requested to schedule a follow-up audit. The object of the audit is "to determine whether the Park Board is following State and Local laws and Procedures for Procurement."

The audit will rely on inquiries, observations, and testing of controls to obtain sufficient documentation to provide assurance laws and procedures were followed. The City Auditor will write an audit program similar to the audit they performed on the city's procurement procedures. The scope will be based on actions accomplished by management and staff as of the approval/implementation date. The audit will likely include 3 areas for testing:

1. Control Activities – Procedures and Controls are in place to provide reasonable assurance that purchases are procured only for allowable purchases and in accordance with the Park Board's procurement policies and procedures.
2. Information and Communication. Procedures and Controls are in place to provide reasonable assurance that the entity identifies, captures, and exchanges information enabling people to carry out their responsibilities.
3. Monitoring. Procedures and Controls are in place to provide reasonable assurance that the effectiveness of internal controls over procurement over time is being appropriately assessed.

The areas tested will be given either an Implemented, In Progress, Not Applicable, or Not Implemented status by the City Auditor. The audit report will be provided to the Park Board and City Council.

**Staff Recommendation:** Staff recommends discussing the audit at the committee level and addressing any questions or concerns committee members may have before scheduling the audit.



# City of Galveston

City Auditor's Office  
City Follow-Up 2023-3  
December 28, 2022

## Engagement Letter Park Board Procurement Follow-Up Audit

Bryson Frazier, Chief Financial Officer  
Galveston Park Board of Trustees  
601 23<sup>rd</sup> St  
Galveston, TX 77550

Dear Mr. Frazier,

The City Auditor's Office wants to schedule a Follow-Up Audit on the Park Board's Procurement Procedures. This audit will tentatively begin on January 1, 2023, and will be conducted by Carrie Sumrall. The Follow-Up Audit process includes:

- Planning
- Entrance meeting (to be scheduled).
- Fieldwork (detailed testing, interviews, etc.).
- Summation of fieldwork results emailed to the Department Head for comment.
- Report preparation.
- Report sent to City Manager for comment.
- Submitted to Council for approval.
- Posted on the City website under the Audit Department.

The objective of the Follow-Up Audit is to determine whether the Park Board is following State and Local laws and Procedures for Procurements.

The Follow-Up Audit will rely on inquiries, observations, and testing of controls, to obtain sufficient documentation to provide assurance on the Follow-Up Audit Objectives.

The scope of the Follow-Up Audit will be based on actions accomplished by management and staff as of the approval/implementation date. In preparation for the start of the fieldwork phase, and with your approval, we will coordinate the Follow-Up Audit with you or your appropriate designee. As part of the planning process, we will schedule an Entrance meeting to provide additional information regarding the Follow-Up Audit.

If you have any questions or concerns, please let me know.

Sincerely,

Carrie Sumrall, Assistant City Auditor, CFE, IAP, CICA, CCS, CTCM  
cc: Glenn Bulgherini

## Appendix A

Follow-Up Procurement Department Administrative Procedures and Controls	Status
<b>Key for Status Descriptions</b>	
<b>Implemented:</b> when the City Management or Staff provided sufficient and appropriate evidence to support all recommendation element.	
<b>In Progress:</b> when the City has plans to begin or has already started to implement and intends to implement the recommendations thoroughly.	
<b>Not Applicable:</b> when the evidence did not support meaningful movement toward implementation and is no longer applicable due to changes in procedures or technology.	
<b>Not Implemented:</b> when evidence did not support meaningful movement toward implementation, when no evidence was provided, when implementation will take time and is in the process but has not measurable progress yet, or when a new recommendation has been issued in the last three months.	
<b>1. Control Activities. Procedures and Controls are in place to provide reasonable assurance that purchases are procured only for allowable purchases and in accordance with the City's Procurement Policies and Procedures. standards. Items a. - i. below should be in writing.</b>	
a. Documentation is in place that provides reasonable assurance that the employee has determined the most appropriate and effective method of purchasing services and commodities for the City. (Internal Quote Form).	<b>Implemented</b>
b. Documentation is in place to provide reasonable assurance that the employee used these factors for purchasing: 1. Conforming to standards of ethical conduct, and 2. complying with all applicable laws, rules and regulations. 3. Meeting the needs of the department while ensuring that the method selected achieves best value.	<b>Implemented</b>
c. Documentation is provided with appropriate authorization and purchasing document in the form of a purchase order that includes the terms and conditions. <b>(Contract includes terms, End User submits PO thru acct prog for approval)</b>	<b>Implemented</b>
d. Documentation is in place that provides reasonable assurance that management, and employees are free from Conflict of Interest by filling out the (CIS) form.	<b>Implemented</b>
e. A standard Procurement file checklist is used and files are completed with all the required documentation and approver conditions. Including requisition, purchase orders, quotations, comparative bids and notes. <b>(Part of Bid Packet)</b>	<b>Implemented</b>
f. Documentation is placed in the City's shared drive prior to the requisition submittal and as documentation is processed.	<b>Implemented</b>
g. Documentation is provided for Sole Source Purchases in accordance with applicable City, State, and Federal regulations.	<b>Implemented</b>
h. Purchasing Department takes the appropriate action to proved each designated departmental employee to have an understanding of the City's Procurement Policies and Procedures as it becomes necessary.	<b>Implemented</b>
i. Documentation is provided for Solicitation Tabulation with pricing, scoring and individuals that scored the vendor. <b>(Part of the Bid Packet)</b>	<b>Implemented</b>
<b>2. Information and Communication. Procedures and Controls are in place to provide reasonable assurance that the entity identifies, captures, and exchanges information enabling people to carry out</b>	

## Appendix A

Follow-Up Procurement Department Administrative Procedures and Controls	Status
their responsibilities. Items a. - c. below should be in writing.	
a. Proof is provided that the City advertised the procurement opportunity in the Galveston Daily News and City's website is consistent with applicable law. <b>(Part of the Bid Packet)</b>	<b>Implemented</b>
b. Documentation is provided for any communication between City employees and vendors during the procurement process. These include emails, letters, and notes from a phone conversation in the file.	<b>Implemented</b>
<b>3. Monitoring. Procedures and Controls are in place to provide reasonable assurance that the effectiveness of internal controls over procurement over time is being appropriately assessed. Items a. below should be in writing.</b>	
a. Documentation that management periodically reviews procurement policies, procedures, and controls used. (Purchasing Manager does annually or as required)	<b>Implemented</b>



---

**Agenda Item:** Discuss and Consider Approval of Fiscal Year 2022 September Unaudited Financial Statements

**Background:** Below are the financial highlights as of September 30, 2022:

**Quick Observations:**

Net income was roughly \$6.8 million after FEMA. The performance of the local and state HOT collections are responsible for most of the increase to net income compared to last year. The Park Board collected \$19.5 million (Park Board's allocation – local and state combined) in HOT in FY2022, compared to roughly \$16 million in FY2021. Overall, operating revenues were up \$4.8 million over last year. Other factors contributing to the positive net income include:

- Received \$931.3k in FEMA reimbursements related to multiple projects across three different funds
- Received \$311k transfer from GLO for Beach Patrol services
- Collected \$195k in auction proceeds – auction of Park Board assets occurred in February 2022

**Income Statement:**

- **Revenues:**

YTD operating revenues, not including interfund transfers, exceeded budget by roughly \$6.4 million, totaling roughly \$26.8 million. The main causes for this were HOT collections coming in higher than budget (both local and state), the transfer from the GLO, and FEMA reimbursements received for previously completed projects related to Ike. The FEMA reimbursements can be broken down as follows:

- Beach Cleaning - \$188.2k
- Dellanera Park - \$142.3k
- R.A. Apffel - \$393.4k
- Stewart Beach - \$40.6k
- Seawolf Park - \$166.8k

Overall, YTD local HOT collections were roughly \$4.8 million higher than budget, and the YTD state rebate was roughly \$2.1 million higher than budget. Total HOT collections (local and state) were \$3.5 million higher than FY2021 actuals.

Park admissions for FY2022 were approximately \$5.42 million, which was \$140k lower than last year, and \$52k lower than budget.

Stewart Beach admissions were down \$291k compared to FY2021, but the drainage project kept the park closed through most of May 2022. R.A. Apffel admissions were up \$130k compared to FY2021 – this is likely due to the increased visitation while Stewart Beach was closed and increased popularity of the park.

Seawolf Park fishing revenue was down \$55k compared to budget, and \$77k down compared to FY2021. This is due to the flounder moratorium in the fall of 2021, but an improvement from the original projection of \$95k in fishing revenue loss at the beginning of the moratorium. Fishing revenue may be down, but admissions at Seawolf were \$42k over budget (\$23k lower than FY2021 actuals). The sub and ship admissions were up \$34k over budget and \$21.6k over FY2021 actuals. Overall, Seawolf's total revenue was \$79k lower than last year.

Concession revenue totaled \$620k in FY2022, roughly \$69.5k over FY2021 actuals.

Grant revenues totaled \$4.5 million – \$1.5 million received from the GLO for the Stewart Beach drainage project and \$3 million from TCEQ/RESTORE for the Babe’s Beach BUDM project.

- **Expenses:**

YTD operating expenses, excluding interfund transfers, came in at roughly \$19.9 million, roughly \$2.9 million, or 12.8%, lower than budget.

Personnel expenses totaled roughly \$10.3 million, and were \$616.2k, or 5.7% lower than budget. It should be noted that the budget variance for personnel expenses at 8/31/2022 was 912k under budget, at 5/30/2022 it was \$1.2 million under budget, and at 3/31/2022 it was \$1.4 million under budget – the increases to seasonal and some full-time pay rates has resulted in more positions being filled and the employee turnover rate being reduced by 12%. As predicted, the variance continued to shrink as the year progressed. The actions taken by the board to address labor issues have been effective.

Materials, Services, and Supplies totaled roughly \$7.8 million, that’s roughly \$884k, or 10.1% under budget. As predicted, the negative budget variance was eliminated in the September unaudited financial statements.

Capital Outlay totaled roughly \$1.2 million (GASB requires that enterprise fund capital outlays be capitalized as assets at yearend and placed on the balance sheet, thus, the actual capital outlay on the income statement is less than the \$1.2 million mentioned above - \$1.2 million in capital outlay less \$658.6k in capitalized assets = \$540.9k which matches the income statement). Capital outlay includes:

- \$144k wheel loader for CZM
- \$236k motor grader for CZM
- \$54k skid steer loader for CZM
- \$8.5k 4WD UTV for CZM
- \$30k on two side-by-side vehicles for Beach Patrol
- \$23k for a wave boat for Beach Patrol
- \$6.5k in capital improvements at the Plaza (flashing replacement)
- \$453k on equipment and improvements for the mobile amenities project at Stewart Beach
- \$15k slab improvement project at Seawolf Park
- \$9k sidewalk install at Seawolf Park

Debt service totaled \$45k (payments for the line of credit, Plaza, and CZM facility).

FEMA expenditures totaled roughly \$24k, and include small repairs at CZM, Stewart Beach, and Seawolf Park.

### **Balance Sheet**

The FY2022 Balance Sheet is healthy. Not including Moody Gardens assets, total assets are approximately \$46.1 million and total liabilities were \$13.2 million.

- As of September 30, 2022, cash totaled roughly \$28.3 million, up roughly \$8.3 million from cash at 9/30/2021. The FY2022 ending cash balance was historically strong. It should be noted that pursuant to

ordinances 22-073 and 22-074, the Park Board transferred \$14.2 million to the City. As of January 6, 2023, there is \$10.7 million in the bank.

- For a full picture of the cash flows, please refer to the Statement of Cash Flows.

Of the \$28.3 million in cash, roughly \$12.4 million is operating cash and \$15.8 million is restricted. It should be noted that there was a \$3 million payment to the GLO for the Babe's Beach BUDM project that was accrued to FY2022, however, the cash was still in the bank at 9/30/2022. The expense cleared the bank in October 2022, and the expense was reimbursed by RESTORE in November 2022.

### **Financial Ratios:**

- Current ratio: 3.7

The current ratio is a liquidity ratio. That means the Park Board has \$3.7 in current assets for every \$1 in current liabilities. Anything over 1 is desirable, and 3.7 is good. It's down from 9.9 in August. This is because of a \$1.3 million increase in accounts payable related to yearend expense accruals, a \$3.8 increase in accrued liabilities (\$3 million of which is the accrued Babe's Beach BUDM project expense), and a \$1.2 million increase in pass-thru funds which is HOT tax owed to the City that was still in the bank as of 9/30/2022. This is typical for a yearend month.

- Quick ratio: 3

Again, another liquidity ratio. This ratio measures cash over current liabilities. 3 is a good quick ratio. It is down from August's quick ratio for the same reasons the current ratio is down.

- Solvency ratio: 0.94

This ratio takes unrestricted/operating cash and divides it by total liabilities. It shows how much of total liabilities can be satisfied by unrestricted cash. The Park Board has \$0.94 in unrestricted cash for every \$1 of total liabilities. Anything over 0.20 is good. The Park Board continues to be a very solvent organization.

- Debt leverage ratio: 0.02

This means that roughly 2% of our total assets, not including Moody Gardens assets, are financed by debt. Anything less than 50% is good. There is room to take on additional debt.

- Working capital: \$25.3 million

Working capital is a measure of an organization's liquidity, operational efficiency, and its short-term financial health. It is calculated by reducing current assets by current liabilities. The Park Board had a strong positive working capital at 9/30/2022.

### **Hotel Occupancy Tax:**

YTD HOT collections were the best on record with a penny value just under \$3.3 million. That's roughly \$800k higher than FY2021's penny value of \$2.5 million, which was a record at that time. While FY2022 collections were at all-time highs, August 2022 broke the 15 consecutive month streak of record HOT collections. The September 2022 penny value \$262k was also less than the September 2021 penny value. The September 2022 penny value was \$262k, and in September 2021 it was \$272k.

Short-term rental portion of total HOT collections was 53% in FY2022.

**Staff Recommendation:** Staff recommends approval of the fiscal year 2022 September unaudited financial statements.



**GALVESTON ISLAND**  
*Park Board of Trustees*

**Financial Statements**

**for the month ended September 30, 2022**

Unaudited

**Galveston Park Board of Trustees**  
**Summarized - YTD Consolidated Income Statement**  
**October 1, 2021 to September 30, 2022**

	Current YTD Actual	Prior YTD Actual	Current Year Change	Current Year % Change	YTD Budget	YTD Budget Variance	YTD Budget Variance %
<b>Revenue:</b>							
Operating Revenue	26,798,512	22,646,289	4,152,223	18.3%	20,406,726	6,391,786	31.3%
Interfund Transfers	3,656,914	2,978,147	678,767	22.8%	3,185,470	471,444	14.8%
<b>Total Operating Revenue</b>	<b>30,455,426</b>	<b>25,624,436</b>	<b>4,830,990</b>	<b>18.9%</b>	<b>23,592,196</b>	<b>6,863,230</b>	<b>29.1%</b>
<b>Expenses:</b>							
Personnel Expenses	10,284,209	8,611,894	1,672,315	19.4%	10,900,382	616,173	5.7%
Materials/Supplies/Services	7,834,541	6,010,169	1,824,372	30.4%	8,718,428	883,887	10.1%
Interfund Transfers	3,656,914	2,978,147	678,767	22.8%	3,185,470	(471,444)	-14.8%
Special Projects	1,790,767	1,545,057	245,710	15.9%	3,220,994	1,430,227	44.4%
<b>Total Operating Expense</b>	<b>23,566,431</b>	<b>19,145,267</b>	<b>4,421,164</b>	<b>23.1%</b>	<b>26,025,274</b>	<b>2,458,843</b>	<b>9.4%</b>
<b>Net Operating Income</b>	<b>6,888,995</b>	<b>6,479,169</b>	<b>409,826</b>	<b>6.3%</b>	<b>(2,433,078)</b>	<b>(9,322,073)</b>	<b>383.1%</b>
<b>Other Revenue/Expense:</b>							
Loan Proceeds	0	0	0	#DIV/0!	932,000	(932,000)	-100.0%
Grant Proceeds	4,524,637	3,446,584	1,078,053	31.3%	7,317,099	(2,792,462)	-38.2%
Grant Expense	4,519,171	2,712,771	1,806,400	66.6%	7,053,126	(2,533,955)	-35.9%
Debt Service	455,231	575,424	(120,193)	-20.9%	651,780	196,549	30.2%
Capital Outlay	540,961	552,101	(11,140)	-2.0%	1,469,471	928,510	63.2%
<b>Total Other Revenue/Expense</b>	<b>(990,726)</b>	<b>(393,712)</b>	<b>(597,014)</b>	<b>151.6%</b>	<b>(925,278)</b>	<b>(2,315,566)</b>	<b>250.3%</b>
<b>Net Income Excl FEMA</b>	<b>5,898,269</b>	<b>6,085,457</b>	<b>(187,188)</b>	<b>-3.1%</b>	<b>(3,358,356)</b>	<b>9,256,625</b>	<b>-275.6%</b>
<b>FEMA</b>							
FEMA Reimbursement	(931,320)	(377,190)	(554,130)	146.9%	(5,288,219)	(4,356,899)	82.4%
FEMA Expenditures	24,025	112,474	(88,449)	-78.6%	5,547,985	5,523,960	99.6%
<b>Total FEMA</b>	<b>(907,295)</b>	<b>(264,716)</b>	<b>(642,579)</b>	<b>242.7%</b>	<b>259,766</b>	<b>1,167,061</b>	<b>449.3%</b>
<b>Net Income After FEMA</b>	<b>6,805,564</b>	<b>6,350,173</b>	<b>455,391</b>	<b>7.2%</b>	<b>(3,618,122)</b>	<b>10,423,686</b>	<b>-288.1%</b>
Use of Reserves	0	0	0	#DIV/0!	4,258,135	(4,258,135)	-100.0%
<b>Net Income</b>	<b>6,805,564</b>	<b>6,350,173</b>	<b>455,391</b>	<b>7.2%</b>	<b>640,013</b>	<b>6,165,551</b>	<b>963.3%</b>

**Park Board of Trustees  
Balance Sheet  
September 30, 2022**

	September 30, 2022			September 30, 2021			CHANGE
	GOVERNMENTAL	ENTERPRISE	TOTAL	GOVERNMENTAL	ENTERPRISE	TOTAL	
	FUNDS	FUNDS		FUNDS	FUNDS		
<b>ASSETS</b>							
CASH	27,289,525	944,325	28,233,850	19,295,200	603,099	19,898,299	8,335,552
INVESTMENTS	0		0	0		0	0
ACCOUNTS RECEIVABLE	5,920,541	2,107	5,922,648	3,089,918	14,431	3,104,349	2,818,299
ALLOWANCE FOR DOUBTFUL ACCOUNTS	0	0	0	0	0	0	0
NET ACCOUNT RECEIVABLES	5,920,541	2,107	5,922,648	3,089,918	14,431	3,104,349	2,818,299
INVENTORY	5,667	8,872	14,539	5,667	4,258	9,925	4,614
PREPAIDS	354,752	227,462	582,214	248,772	175,166	423,938	158,276
NET CAPITAL ASSETS-PARK BOARD	3,293,222	4,240,775	7,533,997	2,160,697	3,824,167	5,984,864	1,549,133
NET CAPITAL ASSETS-MOODY GARDENS	268,123,013	0	268,123,013	283,489,758	0	283,489,758	(15,366,745)
AMOUNT REQUIRED TO RETIRE DEBT	795,852	0	795,852	1,043,292	0	1,043,292	(247,440)
INTERFUND RECEIVABLE	2,797,799	193,179	2,990,979	2,797,799	193,180	2,990,979	0
OTHER ASSETS	30,706	0	30,706	31,621	0	31,621	(915)
<b>TOTAL ASSETS</b>	<b>308,611,077</b>	<b>5,616,721</b>	<b>314,227,798</b>	<b>312,162,724</b>	<b>4,814,301</b>	<b>316,977,025</b>	<b>(2,749,226)</b>
<b>LIABILITIES</b>							
ACCOUNTS PAYABLE	1,520,998	371,437	1,892,435	942,942	165,912	1,108,854	783,581
ACCRUED LIABILITIES	4,159,344	307,007	4,466,351	389,241	298,604	687,845	3,778,506
PASS THRU FUNDS	2,390,030	670,262	3,060,292	1,781,447	770,613	2,552,060	508,232
NOTES PAYABLE	795,852	35,501	831,353	1,043,292	65,099	1,108,391	(277,038)
INTERFUND PAYABLE	0	2,990,979	2,990,979	0	2,990,979	2,990,979	0
<b>TOTAL LIABILITIES</b>	<b>8,866,224</b>	<b>4,375,186</b>	<b>13,241,410</b>	<b>4,156,922</b>	<b>4,291,207</b>	<b>8,448,129</b>	<b>4,793,281</b>
<b>FUND BALANCE</b>							
FUND BALANCE	309,036,657	522,399	309,559,056	317,112,492	121,428	317,233,920	(7,674,864)
EARNINGS	(9,291,804)	719,136	(8,572,668)	(9,106,690)	401,666	(8,705,024)	132,356
<b>TOTAL FUND BALANCE</b>	<b>299,744,853</b>	<b>1,241,535</b>	<b>300,986,388</b>	<b>308,005,802</b>	<b>523,094</b>	<b>308,528,896</b>	<b>(7,542,508)</b>
<b>NET EQUITY</b>	<b>308,611,077</b>	<b>5,616,721</b>	<b>314,227,798</b>	<b>312,162,724</b>	<b>4,814,301</b>	<b>316,977,025</b>	<b>(2,749,227)</b>

**Park Board of Trustees of the City of Galveston**  
**Statement of Cash Flows**  
**As of December 31, 2019**

(In Whole Numbers)

	<u>Governmental</u>	<u>Enterprise</u>	<u>Consolidated</u>
<b>Cash Flows from Operating Activities</b>			
Net Increase/(Decrease) from Operations	6,591,132	1,466,040	8,057,172
Inventories- Decrease/(Increase)	0	(4,614)	(4,614)
Accounts Receivable - Decrease/(Increase)	(2,537,675)	12,324	(2,525,351)
Prepays - Decrease/(Increase)	(105,980)	(52,295)	(158,275)
Accounts Payable - Decrease/(Increase)	4,858,282	136,685	4,994,967
Accrued Liabilities - Decrease/(Increase)	98,460	(23,107)	75,353
Due From Due To - Decrease/(Increase)	0	0	0
<b>Total Cash Flows from Operating Activities</b>	<b>8,904,219</b>	<b>1,535,033</b>	<b>10,439,252</b>
<b>Cash Flows from Investing Activities</b>			
Petty Cash	0		0
Investment Securities-(Increase)/Decrease	916	0	916
FEMA/Insurance Expenditures-(Increase)/Decrease	(145)	(23,880)	(24,025)
Capital Expenditures-(Increase)/Decrease	(531,901)	(293,201)	(825,102)
Capital Assets	448,526	(752,178)	(303,653)
Depreciation	(448,526)	(72,148)	(520,674)
<b>Total Cash Flows from Investing Activities</b>	<b>(531,131)</b>	<b>(1,141,407)</b>	<b>(1,672,538)</b>
<b>Cash Flows from Financing Activities</b>			
Increase / (Decrease) in bank loans	(237,516)	(29,598)	(267,114)
Increase / (Decrease) long term debt	0		0
Increase / (Decrease) in capital leases	(141,248)	(22,801)	(164,049)
<b>Total Cash Flows from Financing Activities</b>	<b>(378,764)</b>	<b>(52,399)</b>	<b>(431,163)</b>
<b>Net Increase (Decrease) In Cash and Cash Equivalents</b>	<b>\$ 7,994,324</b>	<b>\$ 341,227</b>	<b>\$ 8,335,552</b>
<b>Beginning Cash 10/01/2021</b>			19,882,620
<b>Beginning Petty Cash 10/01/2021</b>			15,679
Cash increase/(decrease)			8,335,552
<b>Ending Cash 09/30/2022</b>			<b>28,233,850</b>
Cash Equivalents			0
Bond Discount			0
Total Cash Equivalents			0
<b>Ending Cash &amp; Cash Equivalents 09/30/2022</b>			<b>28,233,850</b>

**Park Board of Trustees**  
**Cash as of September 30, 2022**

	Pooled Cash - General Fund							Restricted Unpooled Cash - Maintained in Separate Funds				TOTAL		
	HOTEL TAX	PARKING	FEMA ADVANCE	HOTEL OCCUPANCY TAX COLLECTIONS	JUNIOR GUARD	Petty Cash	OPERATING	TOTAL POOLED	SAND REPLENISHMENT	SERIES 94	SERIES 99	Construction/Special Project	UNPOOLED	Total Cash
BEACH CLEANING							\$ 5,010,905	\$ 5,010,905					\$ -	\$ 5,010,905
BEACH PATROL	\$ 315,990				\$ 125,122	\$ 100	\$ 4,837,255	\$ 5,278,468					\$ -	\$ 5,278,468
DEBT SERVICE							\$ (29,722)	\$ (29,722)		\$ -	\$ 75,113	\$ 355,098	\$ 430,211	\$ 400,489
DELLANERA PARK			\$ 200,588			\$ 1,128	\$ 88,516	\$ 290,232					\$ -	\$ 290,232
EAST END LAGOON							\$ 64,268	\$ 64,268					\$ -	\$ 64,268
GENERAL FUND-ADMIN GRANTS				\$ 826,244		\$ 200	\$ 735,869	\$ 1,562,313					\$ -	\$ 1,562,313
NOURISHED BEACH	\$ 2,650,883						\$ -	\$ -					\$ -	\$ -
R. A. APFFEL PARK						\$ 5,000	\$ 324,733	\$ 2,975,616					\$ -	\$ 2,975,616
SAND REPLENISHMENT		\$ -					\$ (1,320,670)	\$ (1,315,670)					\$ -	\$ (1,315,670)
SEAWOLF PARK			\$ 66,863				\$ (1,771)	\$ (1,771)	\$ 233				\$ 233	\$ (1,538)
STEWART BEACH						\$ 700	\$ 754,954	\$ 822,517					\$ -	\$ 822,517
TOURISM DEVELOPMENT	\$ 10,464,240					\$ 6,700	\$ 417,850	\$ 424,550					\$ -	\$ 424,550
URBAN PARK (SEAWALL PKG)		\$ 709,170					\$ -	\$ 12,012,531					\$ -	\$ 12,012,531
	\$ 13,431,114	\$ 709,170	\$ 267,451	\$ 826,244	\$ 125,122	\$ 13,828	\$ 12,430,478	\$ 27,803,406	\$ 233	\$ -	\$ 75,113	\$ 355,098	\$ 430,444	\$ 28,233,850

Dellanera Park	\$ 88,516
R. A. Apfell	\$ (1,320,670)
Stewart Beach	\$ 417,850
Seawolf Park	\$ 754,954
Urban Park	\$ -
	<u>\$ (59,350)</u>

Beach Cleaning	\$ 5,010,905
Beach Patrol	\$ 4,837,255
Debt Service	\$ (29,722)
East End Lagoon	\$ 64,268
General Fund	\$ 735,869
Grants	\$ -
Nourished Beach	\$ 324,733
Sand Replenishment	\$ (1,771)
Tourism Develop	\$ 1,548,291
	<u>\$ 12,489,828</u>
Operating Cash	<u>\$ 12,430,478</u>

Park Board of Trustees of the City of Galveston  
 Statement of Revenues and Expenditures  
 From 9/1/2022 Through 9/30/2022

(In Whole Numbers)

	Current Period	Prior Year	Current Period	Current	Current Period	Current	Current	Current Year-To-	Prior Year-To-	Current Year	Current	YTD Budget	Total Budget	Total Budget
	Actual	Actual	Change	Period %	Budget	Budget Variance	% of Change	Date Actual	Date Actual	Change	Year %	Variance	Total Budget	Variance
Revenues														
Hotel Tax - City	1,038,098.00	1,304,689.00	(266,591.00)	-20.4%	854,032.00	184,066.00	21.6%	13,170,575.00	10,116,956.00	3,053,619.00	30.2%	4,770,575.00	8,400,000.00	4,770,575.00
State Hotel Tax Rebate	435,266.00	1,211,355.00	(776,089.00)	-64.1%	464,518.00	(29,252.00)	-6.3%	6,302,793.00	5,852,862.00	449,931.00	7.7%	2,102,793.00	4,200,000.00	2,102,793.00
Park Admissions	443,216.00	291,968.00	151,248.00	51.8%	486,618.00	(43,402.00)	-8.9%	5,420,185.00	5,560,110.00	(139,925.00)	-2.5%	(52,204.00)	5,472,389.00	(52,204.00)
GLO State Reimbursement	0.00	0.00	0.00	0.0%	411,000.00	(411,000.00)	-100.0%	311,000.00	69,721.00	241,279.00	0.0%	(100,000.00)	411,000.00	(100,000.00)
City/County Reimbursement	200,000.00	200,000.00	0.00	0.0%	250,000.00	(50,000.00)	-20.0%	250,000.00	250,000.00	0.00	0.0%	0.00	250,000.00	0.00
Insurance Reimbursement	0.00	15,790.00	(15,790.00)	-100.0%	93,000.00	(93,000.00)	-100.0%	69,741.00	21,437.00	48,304.00	225.3%	(23,259.00)	93,000.00	(23,259.00)
Loan Proceeds	0.00	(298,855.00)	298,855.00	-100.0%	932,000.00	(932,000.00)	-100.0%	0.00	0.00	0.00	0.0%	(932,000.00)	932,000.00	(932,000.00)
Grant Proceeds	3,074,850.00	298,855.00	2,775,995.00	928.9%	7,284,537.00	(4,209,687.00)	-57.8%	4,524,637.00	3,446,584.00	1,078,053.00	31.3%	(2,792,462.00)	7,317,099.00	(2,792,462.00)
Concession/Leases	119,788.00	50,488.00	69,300.00	137.3%	104,468.00	15,320.00	14.7%	620,802.00	551,327.00	69,475.00	12.6%	(166,558.00)	787,360.00	(166,558.00)
Interest/Investment Income	302.00	1,795.00	(1,493.00)	-83.2%	1,608.00	(1,307.00)	-81.2%	25,090.00	13,409.00	11,681.00	87.1%	5,790.00	19,300.00	5,790.00
Donations	0.00	0.00	0.00	0.0%	0.00	0.00	0.0%	0.00	187.00	(187.00)	0.0%	0.00	0.00	0.00
Miscellaneous	18,696.00	15,265.00	3,431.00	22.5%	104,289.00	(85,593.00)	-82.1%	628,326.00	210,280.00	418,046.00	198.8%	(145,351.00)	773,677.00	(145,351.00)
Total Revenues	5,330,216.00	3,091,350.00	2,238,866.00	72.4%	10,986,069.00	(5,655,854.00)	-51.5%	31,323,149.00	28,356,640.00	2,966,509.00	10.5%	2,667,324.00	28,655,825.00	2,667,324.00
Inter-Fund Transfers	822,441.00	799,968.00	22,473.00	2.8%	342,659.00	479,782.00	140.0%	3,656,914.00	2,978,147.00	678,767.00	22.8%	471,444.00	3,185,470.00	471,444.00
<b>Total Revenue</b>	6,152,657.00	3,891,318.00	2,261,339.00	58.1%	11,328,729.00	(5,176,072.00)	-45.7%	34,980,063.00	31,334,788.00	3,645,275.00	11.6%	3,138,769.00	31,841,295.00	3,138,769.00
Personnel Expenses	1,698,961.00	1,335,121.00	363,840.00	27.3%	1,402,905.00	(296,056.00)	21.1%	10,284,209.00	8,611,894.00	1,672,315.00	19.4%	616,174.00	10,900,382.00	616,174.00
Materials/Supplies/Services	4,240,028.00	1,237,602.00	3,002,426.00	242.6%	9,019,416.00	4,779,388.00	-53.0%	9,629,145.00	7,116,264.00	2,512,881.00	35.3%	3,249,173.00	12,878,318.00	3,249,173.00
Tourism Development Specific	713,367.00	260,337.00	453,030.00	174.0%	2,801,237.00	2,087,870.00	-74.5%	2,724,567.00	1,606,677.00	1,117,890.00	69.6%	168,669.00	2,893,236.00	168,669.00
Special Projects	800,633.00	666,542.00	134,091.00	20.1%	3,223,355.00	2,422,722.00	-75.2%	1,790,767.00	1,545,057.00	245,710.00	15.9%	1,430,227.00	3,220,994.00	1,430,227.00
Debt Service	21,654.00	53,169.00	(31,515.00)	-59.3%	326,440.00	304,786.00	-93.4%	455,231.00	575,425.00	(120,194.00)	-20.9%	196,549.00	651,780.00	196,549.00
<b>Total Operating Expenses</b>	7,474,643.00	3,552,771.00	3,921,872.00	110.4%	16,773,353.00	9,298,710.00	-55.4%	24,883,918.00	19,455,317.00	5,428,601.00	27.9%	5,660,792.00	30,544,711.00	5,660,792.00
Capital Assets	(400,889.00)	16,265.00	(417,154.00)	-2564.7%	1,483,489.00	1,884,378.00	-127.0%	540,961.00	552,100.00	(11,139.00)	-2.0%	928,510.00	1,469,471.00	928,510.00
<b>Total Expenditures</b>	7,073,754.00	3,569,036.00	3,504,718.00	98.2%	18,256,842.00	11,183,088.00	-61.3%	25,424,880.00	20,007,417.00	5,417,463.00	27.1%	6,589,302.00	32,014,182.00	6,589,302.00
Inter-Fund Transfers	822,441.00	799,968.00	22,473.00	2.8%	297,967.00	(524,474.00)	176.0%	3,656,914.00	2,978,147.00	678,767.00	22.8%	(471,444.00)	3,185,470.00	(471,444.00)
<b>Total Expenditures</b>	7,896,195.00	4,369,004.00	3,527,191.00	80.7%	17,885,710.00	10,833,610.00	-60.6%	24,969,648.00	19,431,993.00	5,537,655.00	28.5%	6,392,754.00	31,362,402.00	6,392,754.00
Net Income	(1,743,538.00)	(477,686.00)	(1,265,852.00)	265.0%	(7,226,081.00)	5,482,542.00	-75.9%	5,898,269.00	8,349,223.00	(2,450,954.00)	-29.4%	9,256,626.00	(3,358,357.00)	9,256,626.00
FEMA														
FEMA Reimbursement	0.00	(99,164.00)	99,164.00	-100.0%	(5,288,219.00)	(5,288,219.00)	-100.0%	(931,320.00)	(377,190.00)	(554,130.00)	146.9%	(4,356,899.00)	(5,288,219.00)	(4,356,899.00)
FEMA Expenditures	6,203.00	13,703.00	(7,500.00)	-54.7%	5,545,913.00	5,539,711.00	-99.9%	24,025.00	112,474.00	(88,449.00)	-78.6%	5,523,960.00	5,547,985.00	5,523,960.00
Total FEMA	6,203.00	(85,461.00)	91,664.00	-107.3%	257,694.00	251,492.00	-97.6%	(907,295.00)	(264,716.00)	(642,579.00)	242.7%	1,167,061.00	259,766.00	1,167,061.00
<b>Net Income - Including FEMA</b>	(1,749,741.00)	(392,225.00)	(1,357,516.00)	346.1%	(7,483,775.00)	5,734,034.00	-76.6%	6,805,565.00	8,613,939.00	(1,808,374.00)	-21.0%	10,423,688.00	(3,618,123.00)	10,423,688.00
Budget-Use of Reserves	0.00	0.00	0.00	0.0%	4,258,135.00	(4,258,135.00)	-100.0%	0.00	0.00	0.00	0.0%	(4,258,135.00)	4,258,135.00	(4,258,135.00)
Net Income	(1,749,741.00)	(392,225.00)	(1,357,516.00)	346.1%	(3,225,640.00)	1,475,899.00	-45.8%	6,805,565.00	8,613,939.00	(1,808,374.00)	-21.0%	6,165,553.00	640,012.00	6,165,553.00
Depreciation	1,299,528.00	1,276,358.00	23,170.00	1.8%	0.00	(1,299,528.00)	0.0%	15,378,233.00	15,055,195.00	323,038.00	2.1%	(15,378,233.00)	0.00	(15,378,233.00)
Net Income	(3,049,269.00)	(1,668,583.00)	(1,380,686.00)	82.7%	(3,225,640.00)	176,371.00	-5.5%	(8,572,668.00)	(6,441,256.00)	(2,131,412.00)	33.1%	(9,212,680.00)	640,012.00	(9,212,680.00)

Park Board of Trustees of the City of Galveston  
Statement of Revenues and Expenditures  
From 9/1/2022 Through 9/30/2022

(In Whole Numbers)

	<b>Current Period</b>	<b>Prior Year</b>	<b>Current Period</b>	<b>Current Period</b>	<b>Current Period</b>	<b>Current Period</b>	<b>Current Period</b>
	<b>Actual</b>	<b>Current Period</b>	<b>Current Period</b>	<b>Percent of</b>	<b>Current Period</b>	<b>Current Period</b>	<b>Budget % of</b>
		<b>Actual</b>	<b>Change</b>	<b>Change</b>	<b>Budget</b>	<b>Budget Variance</b>	<b>Change</b>
Revenues							
Hotel Tax - City	1,038,098.00	1,304,689.00	(266,591.00)	-20%	854,032.00	184,066.00	21.55%
State Hotel Tax Rebate	435,266.00	1,211,355.00	(776,089.00)	-64%	464,518.00	(29,252.00)	-6.29%
Park Admissions	443,216.00	291,968.00	151,248.00	52%	486,618.00	(43,402.00)	-8.91%
GLO State Reimbursement	0.00	0.00	0.00	0%	411,000.00	(411,000.00)	-100.00%
City/County Reimbursement	200,000.00	200,000.00	0.00	0%	250,000.00	(50,000.00)	-20.00%
Insurance Reimbursement	0.00	15,790.00	(15,790.00)	-100%	93,000.00	(93,000.00)	-100.00%
Loan Proceeds	0.00	(298,855.00)	298,855.00	-100%	932,000.00	(932,000.00)	-100.00%
Grant Proceeds	3,074,850.00	298,855.00	2,775,995.00	929%	7,284,537.00	(4,209,687.00)	-57.78%
Concession/Leases	119,788.00	50,488.00	69,300.00	137%	104,468.00	15,320.00	14.66%
Interest/Investment Income	302.00	1,795.00	(1,493.00)	-83%	1,608.00	(1,307.00)	-81.23%
Donations	0.00	0.00	0.00	0%	0.00	0.00	0.00%
Miscellaneous	<u>18,696.00</u>	<u>15,265.00</u>	<u>3,431.00</u>	<u>22%</u>	<u>104,289.00</u>	<u>(85,593.00)</u>	<u>-82.07%</u>
Total Revenues	<u>5,330,216.00</u>	<u>3,091,350.00</u>	<u>2,238,866.00</u>	<u>72%</u>	<u>10,986,069.00</u>	<u>(5,655,854.00)</u>	<u>-51.48%</u>
			0				
Inter-Fund Transfers	<u>822,441.00</u>	<u>799,968.00</u>	<u>22,473.00</u>	<u>3%</u>	<u>342,659.00</u>	<u>479,782.00</u>	<u>140.01%</u>
			0				
Total Revenue	<u>6,152,657.00</u>	<u>3,891,318.00</u>	<u>2,261,339.00</u>	<u>58%</u>	<u>11,328,729.00</u>	<u>(5,176,072.00)</u>	<u>-45.68%</u>
Personnel Expenses							
Recovered Labor	0.00	0.00	0.00	0%	0.00	0.00	0.00%
Salaries - Employees	1,121,475.00	904,047.00	217,428.00	24%	631,326.00	(490,150.00)	77.63%
Overtime Pay	8,100.00	25,417.00	(17,317.00)	-68%	26,537.00	18,437.00	-69.47%
Salaries - Security	29,531.00	30,883.00	(1,352.00)	-4%	25,191.00	(4,341.00)	17.23%
Salary - Incentive	129,963.00	101,909.00	28,054.00	28%	117,933.00	(12,030.00)	10.20%
Contract Labor	8,133.00	17,475.00	(9,342.00)	-53%	56,553.00	48,421.00	-85.61%
Payroll Taxes	87,512.00	89,900.00	(2,388.00)	-3%	51,624.00	(35,888.00)	69.51%
Pension Plan	36,457.00	35,997.00	460.00	1%	25,132.00	(11,326.00)	45.06%
Workers Compensation	11,250.00	9,142.00	2,108.00	23%	22,900.00	11,650.00	-50.87%
TWF - Unemployment	4,799.00	(27,324.00)	32,123.00	-118%	12,341.00	7,543.00	-61.11%
Auto Allowance	1,390.00	1,351.00	39.00	3%	750.00	(640.00)	85.39%
Drug Testing/Background	420.00	670.00	(250.00)	-37%	8,507.00	8,087.00	-95.06%
Employment Fee/Relocation	0.00	4,976.00	(4,976.00)	-100%	2,447.00	2,447.00	-100.00%
Employee Insurance	175,887.00	74,118.00	101,769.00	137%	175,048.00	(838.00)	0.47%
Uniforms	8,840.00	6,456.00	2,384.00	37%	23,056.00	14,216.00	-61.65%
Sick Leave/Vacation Accrual	75,203.00	60,107.00	15,096.00	25%	29,330.00	(45,873.00)	156.39%
Salary Contingency	<u>0.00</u>	<u>0.00</u>	<u>0.00</u>	<u>0%</u>	<u>194,229.00</u>	<u>194,229.00</u>	<u>-100.00%</u>
Total Personnel Expenses	<u>1,698,960.00</u>	<u>1,335,124.00</u>	<u>363,836.00</u>	<u>27%</u>	<u>1,402,905.00</u>	<u>(296,056.00)</u>	<u>21.10%</u>

Park Board of Trustees of the City of Galveston  
Statement of Revenues and Expenditures  
From 9/1/2022 Through 9/30/2022

(In Whole Numbers)

	<b>Current Period</b>	<b>Prior Year</b>	<b>Current Period</b>		<b>Current Period</b>		
	<b>Actual</b>	<b>Current Period</b>	<b>Current Period</b>	<b>Percent of</b>	<b>Current Period</b>	<b>Current Period</b>	<b>Budget % of</b>
		<b>Actual</b>	<b>Change</b>	<b>Change</b>	<b>Budget</b>	<b>Budget Variance</b>	<b>Change</b>
Materials/Supplies/Services							
Alarm System	1,102.00	1,195.00	(93.00)	-8%	2,327.00	1,225.00	-52.63%
Auto/Mileage Reimbursement	1,044.00	2,068.00	(1,024.00)	-50%	16,635.00	15,591.00	-93.72%
Banking Expenses	21,055.00	8,072.00	12,983.00	161%	26,290.00	5,235.00	-19.91%
Buoys	876.00	1,446.00	(570.00)	-39%	10,600.00	9,724.00	-91.73%
Buoys Construction	0.00	0.00	0.00	0%	6,500.00	6,500.00	-100.00%
Cash Over/Short	(208.00)	(63.00)	(145.00)	230%	0.00	208.00	0.00%
City- UP Reserve 15%	90,202.00	100,747.00	(10,545.00)	-10%	78,828.00	(11,374.00)	14.42%
City - UP Maintenance/Repair	580,060.00	669,866.00	(89,806.00)	-13%	52,552.00	(527,508.00)	1003.78%
Community Awareness	401.00	0.00	401.00	0%	12,200.00	11,799.00	-96.71%
Contract Services - Miscellaneous	14,222.00	7,309.00	6,913.00	95%	256,795.00	242,573.00	-94.46%
Contract Services - Copy Leases	2,073.00	2,082.00	(9.00)	0%	3,760.00	1,688.00	-44.87%
Contract Service - Dumping Fees	3,222.00	12,710.00	(9,488.00)	-75%	6,083.00	2,862.00	-47.04%
Contract Services - Port-a-Lets	8,405.00	5,185.00	3,220.00	62%	8,596.00	191.00	-2.22%
Cost of Sales	(2,629.00)	1,354.00	(3,983.00)	-294%	4,300.00	6,929.00	-161.14%
Data Processing/Software	1,784.00	3,115.00	(1,331.00)	-43%	24,275.00	22,491.00	-92.65%
Maintenance							
Discounts	0.00	0.00	0.00	0%	0.00	0.00	0.00%
Dues and Subscriptions	(2,369.00)	(5,615.00)	3,246.00	-58%	38,205.00	40,574.00	-106.20%
Equipment Rental	5,153.00	14,393.00	(9,240.00)	-64%	33,268.00	28,115.00	-84.51%
Gasoline	49,561.00	17,436.00	32,125.00	184%	14,825.00	(34,737.00)	234.31%
Grant - Other	3,045,788.00	5,434.00	3,040,354.00	55951%	7,020,564.00	3,974,776.00	-56.61%
Insurance	2,535.00	53,966.00	(51,431.00)	-95%	59,344.00	56,809.00	-95.72%
Junior Life Guard Expenditures	392.00	1,045.00	(653.00)	-62%	29,815.00	29,423.00	-98.68%
Licenses	50.00	1,115.00	(1,065.00)	-96%	1,346.00	1,296.00	-96.28%
Office Lease	83,806.00	30,808.00	52,998.00	172%	18,526.00	(65,279.00)	352.35%
Maintenance and Repair -	7,005.00	33,877.00	(26,872.00)	-79%	28,090.00	21,085.00	-75.06%
Maintenance and Repair -	19,847.00	31,048.00	(11,201.00)	-36%	39,279.00	19,433.00	-49.47%
Meetings and Seminars	9,488.00	4,111.00	5,377.00	131%	58,192.00	48,705.00	-83.69%
Memberships	(35,813.00)	(3,041.00)	(32,772.00)	1078%	131,195.00	167,008.00	-127.29%
Miscellaneous	57,897.00	20,807.00	37,090.00	178%	76,674.00	18,777.00	-24.48%
Postage	2,295.00	9,800.00	(7,505.00)	-77%	10,000.00	7,705.00	-77.05%
Postage - Courier Service	239.00	699.00	(460.00)	-66%	7,350.00	7,111.00	-96.74%
Professional Services - Auditors	0.00	0.00	0.00	0%	5,981.00	5,981.00	-100.00%

Park Board of Trustees of the City of Galveston  
Statement of Revenues and Expenditures  
From 9/1/2022 Through 9/30/2022

(In Whole Numbers)

	Prior Year			Current Period		Current Period	
	Current Period Actual	Current Period Actual	Current Period Change	Percent of Change	Current Period Budget	Current Period Budget Variance	Budget % of Change
Professional Services - Legal	141,107.00	19,367.00	121,740.00	629%	57,458.00	(83,649.00)	145.58%
Professional Services - Other	24,338.00	92,108.00	(67,770.00)	-74%	567,378.00	543,041.00	-95.71%
Radios	(426.00)	(1,983.00)	1,557.00	-79%	4,828.00	5,254.00	-108.82%
Signage	4,860.00	14,118.00	(9,258.00)	-66%	77,786.00	72,926.00	-93.75%
Small Tools & Equipment	28,843.00	11,012.00	17,831.00	162%	47,074.00	18,231.00	-38.72%
Supplies - Cleaning	1,242.00	912.00	330.00	36%	3,555.00	2,313.00	-65.06%
Supplies - First Aid	1,408.00	12,056.00	(10,648.00)	-88%	5,476.00	4,069.00	-74.29%
Supplies - Office	4,294.00	4,985.00	(691.00)	-14%	12,702.00	8,408.00	-66.19%
Supplies - Other	4,774.00	5,740.00	(966.00)	-17%	3,138.00	(1,636.00)	52.12%
Supplies - Paper Goods	215.00	2,164.00	(1,949.00)	-90%	2,219.00	2,004.00	-90.31%
Supplies - Stock Batteries, Oil, Flammable	2,395.00	496.00	1,899.00	383%	3,058.00	663.00	-21.66%
Supplies - Welding	851.00	361.00	490.00	136%	650.00	(201.00)	30.93%
Tickets - Gate Admissions	4,986.00	2,554.00	2,432.00	95%	4,628.00	(357.00)	7.71%
Tower Construction	0.00	0.00	0.00	0%	6,660.00	6,660.00	-100.00%
Training	3,304.00	5,831.00	(2,527.00)	-43%	97,063.00	93,759.00	-96.59%
Trash Barrels	0.00	0.00	0.00	0%	1,958.00	1,958.00	-100.00%
Trash Barrel Liners	1,995.00	0.00	1,995.00	0%	1,576.00	(419.00)	26.55%
Utilities - Electricity/Gas/Water	31,430.00	18,520.00	12,910.00	70%	19,500.00	(11,930.00)	61.18%
Utilities - Telephone	16,932.00	18,393.00	(1,461.00)	-8%	20,315.00	3,383.00	-16.65%
Total Materials/Supplies/Services	<u>4,240,031.00</u>	<u>1,237,603.00</u>	<u>3,002,428.00</u>	<u>243%</u>	<u>9,019,416.00</u>	<u>4,779,388.00</u>	<u>-52.99%</u>
Tourism Development Specific							
Advertising and Promotions	425.00	10,136.00	(9,711.00)	-96%	62,842.00	62,417.00	-99.32%
Advertising - R. A. Apffel	9,133.00	9,991.00	(858.00)	-9%	60,000.00	50,867.00	-84.77%
Advertising - Stewart Beach	20,741.00	28,645.00	(7,904.00)	-28%	60,000.00	39,259.00	-65.43%
Collateral	8,026.00	30,542.00	(22,516.00)	-74%	152,725.00	144,699.00	-94.74%
Floral/Client Amenities	0.00	294.00	(294.00)	-100%	1,500.00	1,500.00	-100.00%
Marketing Coop	0.00	500.00	(500.00)	-100%	30,700.00	30,700.00	-100.00%
Marketing Travel	20,624.00	39,337.00	(18,713.00)	-48%	124,400.00	103,776.00	-83.42%
Media Placement	498,286.00	32,429.00	465,857.00	1437%	1,796,800.00	1,298,514.00	-72.26%
Media Production	6,498.00	5,600.00	898.00	16%	10,000.00	3,503.00	-35.02%
Photography	5,691.00	6,353.00	(662.00)	-10%	10,000.00	4,309.00	-43.08%
Preplacement	0.00	0.00	0.00	#DIV/0!	5,000.00	5,000.00	-100.00%
Promotion Materials	44,805.00	25,770.00	19,035.00	74%	84,796.00	39,991.00	-47.16%
Public Relations	19,184.00	28,187.00	(9,003.00)	-32%	82,500.00	63,316.00	-76.74%
Sales Incentive	66,932.00	33,085.00	33,847.00	102%	263,000.00	196,068.00	-74.55%
Site Tours/Convention Solicitation	<u>13,021.00</u>	<u>9,468.00</u>	<u>3,553.00</u>	<u>38%</u>	<u>56,975.00</u>	<u>43,954.00</u>	<u>-77.14%</u>
Total Tourism Development	<u>713,366.00</u>	<u>260,337.00</u>	<u>453,029.00</u>	<u>174%</u>	<u>2,801,237.00</u>	<u>2,087,870.00</u>	<u>-74.53%</u>

Park Board of Trustees of the City of Galveston  
Statement of Revenues and Expenditures  
From 9/1/2022 Through 9/30/2022

(In Whole Numbers)

	<b>Current Period</b>	<b>Prior Year</b>	<b>Current Period</b>	<b>Current Period</b>	<b>Current Period</b>	<b>Current Period</b>	<b>Current Period</b>
	<b>Actual</b>	<b>Current Period</b>	<b>Current Period</b>	<b>Percent of</b>	<b>Current Period</b>	<b>Current Period</b>	<b>Budget % of</b>
	<b>Actual</b>	<b>Actual</b>	<b>Change</b>	<b>Change</b>	<b>Budget</b>	<b>Budget Variance</b>	<b>Change</b>
Special Projects							
Special Projects	412,514.00	363,431.00	49,083.00	14%	1,049,396.00	636,882.00	-60.69%
Unforeseen Special Projects	64,197.00	295,442.00	(231,245.00)	-78%	1,200,000.00	1,135,803.00	-94.65%
Contingency - Board Approval Required	<u>323,922.00</u>	<u>7,669.00</u>	<u>316,253.00</u>	4124%	<u>973,959.00</u>	<u>650,037.00</u>	-66.74%
Total Special Projects	<u>800,633.00</u>	<u>666,542.00</u>	<u>134,091.00</u>	<u>20%</u>	<u>3,223,355.00</u>	<u>2,422,722.00</u>	-75.16%
Debt Service							
Loans	7,496.00	(342.00)	7,838.00	-2292%	305,439.00	297,942.00	-97.54%
Capital Leases	<u>14,158.00</u>	<u>53,511.00</u>	<u>(39,353.00)</u>	-74%	<u>21,002.00</u>	<u>6,844.00</u>	-32.58%
Total Debt Service	<u>21,654.00</u>	<u>53,169.00</u>	<u>(31,515.00)</u>	-59%	<u>326,440.00</u>	<u>304,786.00</u>	-93.37%
Total Operating Expenses	<u>7,474,644.00</u>	<u>3,552,775.00</u>	<u>3,921,869.00</u>	#DIV/0! <u>110%</u>	<u>16,773,353.00</u>	<u>9,298,710.00</u>	-55.43%
Capital Assets							
Capital Improvements	(112,594.00)	(101,703.00)	(10,891.00)	11%	1,266,474.00	1,379,068.00	-108.89%
Car Counters & Cameras	0.00	0.00	0.00	0%	0.00	0.00	0.00%
Equipment	(297,745.00)	68,493.00	(366,238.00)	-535%	195,303.00	493,048.00	-252.45%
Gain/Loss on Sale of Equipment	0.00	0.00	0.00	0%	0.00	0.00	0.00%
Landscaping	9,450.00	48,626.00	(39,176.00)	-81%	21,712.00	12,262.00	-56.47%
Leasehold Improvements	<u>0.00</u>	<u>849.00</u>	<u>(849.00)</u>	-100%	<u>0.00</u>	<u>0.00</u>	<u>0.00%</u>
Total Capital Assets	(400,889.00)	<u>16,265.00</u>	(417,154.00)	-2565%	<u>1,483,489.00</u>	<u>1,884,378.00</u>	-127.02%
Total Expenditures	<u>7,073,755.00</u>	<u>3,569,040.00</u>	<u>3,504,715.00</u>	<u>98%</u>	<u>18,256,842.00</u>	<u>11,183,088.00</u>	-61.25%
Inter-Fund Transfers	<u>822,441.00</u>	<u>799,968.00</u>	<u>22,473.00</u>	<u>3%</u>	<u>297,967.00</u>	(524,474.00)	176.01%
Total Expenditures	<u>7,896,196.00</u>	<u>4,369,008.00</u>	<u>3,527,188.00</u>	<u>81%</u>	<u>17,885,710.00</u>	<u>10,833,610.00</u>	-60.57%
Net Income	(1,743,539.00)	(477,690.00)	(1,265,849.00)	265%	(7,226,081.00)	5,482,542.00	-75.87%
FEMA							
FEMA Reimbursement	0.00	(99,164.00)	99,164.00	-100%	(5,288,219.00)	(5,288,219.00)	-100.00%
FEMA Expenditures	<u>6,203.00</u>	<u>13,703.00</u>	<u>(7,500.00)</u>	-55%	<u>5,545,913.00</u>	<u>5,539,711.00</u>	-99.88%
Total FEMA	<u>6,203.00</u>	(85,462.00)	<u>91,665.00</u>	-107%	<u>257,694.00</u>	<u>251,492.00</u>	-97.59%
NI - Including FEMA	(1,749,742.00)	(392,228.00)	(1,357,514.00)	346%	(7,483,775.00)	5,734,034.00	-76.61%
Budget-Use of Reserves	<u>0.00</u>	<u>0.00</u>	<u>0.00</u>	<u>0%</u>	<u>4,258,135.00</u>	(4,258,135.00)	-100.00%

Park Board of Trustees of the City of Galveston  
Statement of Revenues and Expenditures  
From 9/1/2022 Through 9/30/2022

(In Whole Numbers)

	<b>Current Period Actual</b>	<b>Prior Year Current Period Actual</b>	<b>Current Period Change</b>	<b>Current Period Percent of Change</b>	<b>Current Period Budget</b>	<b>Current Period Budget Variance</b>	<b>Current Period Budget % of Change</b>
Net Income	<u>(1,749,742.00)</u>	<u>(392,228.00)</u>	<u>(1,357,514.00)</u>	346%	<u>(3,225,640.00)</u>	1,475,899.00	-45.75%
Depreciation	<u>1,299,528.00</u>	<u>1,276,358.00</u>	<u>23,170.00</u>	2%	<u>0.00</u>	<u>(1,299,528.00)</u>	0.00%
Net Income	<u>(3,049,270.00)</u>	<u>(1,668,586.00)</u>	<u>(1,380,684.00)</u>	83%	<u>(3,225,640.00)</u>	<u>176,371.00</u>	-5.46%

Park Board of Trustees of the City of Galveston  
Consolidated - YTD Statement of Revenues and Expenditures  
From 10/1/2021 Through 9/30/2022

(In Whole Numbers)

	<u>Current Year-To- Date Actual</u>	<u>Prior Year-To-Date Actual</u>	<u>Current Year Change</u>	<u>Current Year % Change</u>	<u>YTD Budget</u>	<u>YTD Budget Variance</u>	<u>Total Budget</u>	<u>Total Budget Variance</u>
Revenues								
Hotel Tax - City	13,170,575.00	10,116,956.00	3,053,619.00	30%	8,400,000.00	4,770,575.00	8,400,000.00	4,770,575.00
State Hotel Tax Rebate	6,302,793.00	5,852,862.00	449,931.00	8%	4,200,000.00	2,102,793.00	4,200,000.00	2,102,793.00
Park Admissions	5,420,185.00	5,560,110.00	(139,925.00)	-3%	5,472,389.00	(52,204.00)	5,472,389.00	(52,204.00)
GLO State Reimbursement	311,000.00	69,721.00	241,279.00	346%	411,000.00	(100,000.00)	411,000.00	(100,000.00)
City/County Reimbursement	250,000.00	250,000.00	0.00	0%	250,000.00	0.00	250,000.00	0.00
Insurance Reimbursement	69,741.00	21,437.00	48,304.00	225%	93,000.00	(23,259.00)	93,000.00	(23,259.00)
Loan Proceeds	0.00	0.00	0.00	0%	932,000.00	(932,000.00)	932,000.00	(932,000.00)
Grant Proceeds	4,524,637.00	3,446,584.00	1,078,053.00	31%	7,317,099.00	(2,792,462.00)	7,317,099.00	(2,792,462.00)
Concession/Leases	620,802.00	551,327.00	69,475.00	13%	787,360.00	(166,558.00)	787,360.00	(166,558.00)
Interest/Investment Income	25,090.00	13,409.00	11,681.00	87%	19,300.00	5,790.00	19,300.00	5,790.00
Donations	0.00	187.00	(187.00)	-100%	0.00	0.00	0.00	0.00
Miscellaneous	628,326.00	210,280.00	418,046.00	199%	773,677.00	(145,351.00)	773,677.00	(145,351.00)
Total Revenues	<u>31,323,149.00</u>	<u>26,092,873.00</u>	<u>5,230,276.00</u>	20%	<u>28,655,825.00</u>	<u>2,667,324.00</u>	<u>28,655,825.00</u>	<u>2,667,324.00</u>
Inter-Fund Transfers	<u>3,656,914.00</u>	<u>2,978,147.00</u>	<u>678,767.00</u>	23%	<u>3,185,470.00</u>	<u>471,444.00</u>	<u>3,185,470.00</u>	<u>471,444.00</u>
<b>Total Revenue</b>	<u>34,980,063.00</u>	<u>29,071,020.00</u>	<u>5,909,043.00</u>	20%	<u>31,841,295.00</u>	<u>3,138,769.00</u>	<u>31,841,295.00</u>	<u>3,138,769.00</u>
Personnel Expenses								
Recovered Labor	0.00	(1,200.00)	1,200.00	-100%	0.00	0.00	0.00	0.00
Salaries - Employees	7,648,129.00	6,243,684.00	1,404,445.00	22%	7,575,334.00	(72,795.00)	7,575,334.00	(72,795.00)
Overtime Pay	96,692.00	147,064.00	(50,372.00)	-34%	166,359.00	69,667.00	166,359.00	69,667.00
Salaries - Security	126,041.00	127,994.00	(1,953.00)	-2%	201,525.00	75,484.00	201,525.00	75,484.00
Salary - Incentive	152,682.00	111,807.00	40,875.00	37%	117,933.00	(34,749.00)	117,933.00	(34,749.00)
Contract Labor	122,884.00	155,313.00	(32,429.00)	-21%	201,720.00	78,836.00	201,720.00	78,836.00
Payroll Taxes	534,292.00	489,844.00	44,448.00	9%	605,955.00	71,663.00	605,955.00	71,663.00
Pension Plan	207,880.00	188,009.00	19,871.00	11%	297,767.00	89,887.00	297,767.00	89,887.00
Workers Compensation	130,940.00	94,090.00	36,850.00	39%	271,015.00	140,075.00	271,015.00	140,075.00
TWF - Unemployment	19,759.00	3,026.00	16,733.00	553%	38,097.00	18,338.00	38,097.00	18,338.00
Auto Allowance	10,369.00	10,488.00	(119.00)	-1%	9,000.00	(1,369.00)	9,000.00	(1,369.00)
Drug Testing/Background	9,996.00	10,486.00	(490.00)	-5%	17,978.00	7,982.00	17,978.00	7,982.00
Employment Fee/Relocation	350.00	5,551.00	(5,201.00)	-94%	3,822.00	3,472.00	3,822.00	3,472.00
Employee Insurance	1,082,808.00	903,816.00	178,992.00	20%	1,088,155.00	5,347.00	1,088,155.00	5,347.00
Uniforms	66,183.00	64,793.00	1,390.00	2%	79,871.00	13,688.00	79,871.00	13,688.00
Sick Leave/Vacation Accrual	75,203.00	57,129.00	18,074.00	32%	31,622.00	(43,581.00)	31,622.00	(43,581.00)
Salary Contingency	0.00	0.00	0.00	0%	194,229.00	194,229.00	194,229.00	194,229.00
Total Personnel Expenses	<u>10,284,209.00</u>	<u>8,611,894.00</u>	<u>1,672,315.00</u>	19%	<u>10,900,382.00</u>	<u>616,174.00</u>	<u>10,900,382.00</u>	<u>616,174.00</u>

Park Board of Trustees of the City of Galveston  
Consolidated - YTD Statement of Revenues and Expenditures  
From 10/1/2021 Through 9/30/2022

(In Whole Numbers)

	Current Year-To- Date Actual	Prior Year-To-Date Actual	Current Year Change	Current Year % Change	YTD Budget	YTD Budget Variance	Total Budget	Total Budget Variance
Materials/Supplies/Services								
Alarm System	13,694.00	16,375.00	(2,681.00)	-16%	15,820.00	2,126.00	15,820.00	2,126.00
Auto/Mileage Reimbursement	5,756.00	5,842.00	(86.00)	-1%	16,635.00	10,879.00	16,635.00	10,879.00
Banking Expenses	238,229.00	261,080.00	(22,851.00)	-9%	297,839.00	59,610.00	297,839.00	59,610.00
Buoys	5,317.00	6,234.00	(917.00)	-15%	10,600.00	5,283.00	10,600.00	5,283.00
Buoys Construction	1,002.00	2,807.00	(1,805.00)	-64%	6,500.00	5,498.00	6,500.00	5,498.00
Cash Over/Short	1,314.00	1,056.00	258.00	24%	0.00	(1,314.00)	0.00	(1,314.00)
City- UP Reserve 15%	282,409.00	265,682.00	16,727.00	6%	315,310.00	32,901.00	315,310.00	32,901.00
City - UP Maintenance/Repair	580,060.00	669,866.00	(89,806.00)	-13%	210,207.00	(369,853.00)	210,207.00	(369,853.00)
Community Awareness	4,174.00	24,037.00	(19,863.00)	-83%	12,200.00	8,026.00	12,200.00	8,026.00
Contract Services - Miscellaneous	327,183.00	306,842.00	20,341.00	7%	441,086.00	113,903.00	441,086.00	113,903.00
Contract Services - Copy Leases	26,476.00	24,155.00	2,321.00	10%	29,175.00	2,699.00	29,175.00	2,699.00
Contract Service - Dumping Fees	42,092.00	49,630.00	(7,538.00)	-15%	64,000.00	21,908.00	64,000.00	21,908.00
Contract Services - Port-a-Lets	72,660.00	52,237.00	20,423.00	39%	65,343.00	(7,317.00)	65,343.00	(7,317.00)
Cost of Sales	21,399.00	3,839.00	18,560.00	654%	12,550.00	(8,849.00)	12,550.00	(8,849.00)
Data Processing/Software Maintenance	222,515.00	178,026.00	44,489.00	25%	219,096.00	(3,419.00)	219,096.00	(3,419.00)
Discounts	0.00	(19.00)	19.00	-100%	0.00	0.00	0.00	0.00
Dues and Subscriptions	22,070.00	20,883.00	1,187.00	6%	38,225.00	16,155.00	38,225.00	16,155.00
Equipment Rental	27,275.00	20,234.00	7,041.00	35%	39,742.00	12,467.00	39,742.00	12,467.00
Gasoline	243,952.00	109,497.00	134,455.00	123%	131,650.00	(112,302.00)	131,650.00	(112,302.00)
Grant - Other	4,519,171.00	2,712,771.00	1,806,400.00	67%	7,053,126.00	2,533,955.00	7,053,126.00	2,533,955.00
Insurance	555,880.00	587,317.00	(31,437.00)	-5%	629,612.00	73,732.00	629,612.00	73,732.00
Junior Life Guard Expenditures	20,902.00	9,896.00	11,006.00	111%	29,815.00	8,913.00	29,815.00	8,913.00
Licenses	2,710.00	3,427.00	(717.00)	-21%	5,815.00	3,105.00	5,815.00	3,105.00
Office Lease	217,996.00	115,360.00	102,636.00	89%	222,316.00	4,320.00	222,316.00	4,320.00
Maintenance and Repair - Buildings	190,036.00	157,701.00	32,335.00	21%	389,593.00	199,557.00	389,593.00	199,557.00
Maintenance and Repair - Equipment	181,765.00	179,248.00	2,517.00	1%	198,879.00	17,115.00	198,879.00	17,115.00
Meetings and Seminars	61,409.00	23,628.00	37,781.00	160%	79,316.00	17,907.00	79,316.00	17,907.00
Memberships	92,997.00	82,917.00	10,080.00	12%	142,045.00	49,048.00	142,045.00	49,048.00
Miscellaneous	152,299.00	74,938.00	77,361.00	103%	242,905.00	90,606.00	242,905.00	90,606.00
Postage	12,283.00	9,775.00	2,508.00	26%	10,000.00	(2,283.00)	10,000.00	(2,283.00)
Postage - Courier Service	6,152.00	5,863.00	289.00	5%	9,267.00	3,115.00	9,267.00	3,115.00
Professional Services - Auditors	66,950.00	65,000.00	1,950.00	3%	70,789.00	3,839.00	70,789.00	3,839.00
Professional Services - Legal	257,409.00	109,023.00	148,386.00	136%	172,500.00	(84,909.00)	172,500.00	(84,909.00)
Professional Services - Other	297,058.00	309,707.00	(12,649.00)	-4%	619,056.00	321,998.00	619,056.00	321,998.00
Radios	15,893.00	19,282.00	(3,389.00)	-18%	41,449.00	25,556.00	41,449.00	25,556.00
Signage	47,681.00	55,885.00	(8,204.00)	-15%	127,255.00	79,575.00	127,255.00	79,575.00

Park Board of Trustees of the City of Galveston  
Consolidated - YTD Statement of Revenues and Expenditures  
From 10/1/2021 Through 9/30/2022

(In Whole Numbers)

	Current Year-To-		Prior Year-To-Date	Current Year	Current Year	YTD Budget		Total Budget	Total Budget
	Date	Actual	Actual	Change	% Change	YTD Budget	Variance	Total Budget	Variance
Small Tools & Equipment		143,844.00	40,949.00	102,895.00	251%	120,654.00	(23,190.00)	120,654.00	(23,190.00)
Supplies - Cleaning		14,773.00	12,645.00	2,128.00	17%	24,288.00	9,514.00	24,288.00	9,514.00
Supplies - First Aid		7,494.00	23,631.00	(16,137.00)	-68%	29,967.00	22,473.00	29,967.00	22,473.00
Supplies - Office		39,470.00	32,635.00	6,835.00	21%	42,821.00	3,352.00	42,821.00	3,352.00
Supplies - Other		32,390.00	21,059.00	11,331.00	54%	33,155.00	765.00	33,155.00	765.00
Supplies - Paper Goods		7,586.00	10,782.00	(3,196.00)	-30%	23,756.00	16,170.00	23,756.00	16,170.00
Supplies - Stock Batteries, Oil, Fluids		9,747.00	983.00	8,764.00	892%	10,391.00	644.00	10,391.00	644.00
Supplies - Welding		5,448.00	5,566.00	(118.00)	-2%	7,800.00	2,352.00	7,800.00	2,352.00
Tickets - Gate Admissions		15,428.00	9,918.00	5,510.00	56%	12,450.00	(2,978.00)	12,450.00	(2,978.00)
Tower Construction		5,036.00	2,267.00	2,769.00	122%	6,660.00	1,624.00	6,660.00	1,624.00
Training		102,453.00	41,941.00	60,512.00	144%	137,537.00	35,084.00	137,537.00	35,084.00
Trash Barrels		15,567.00	12,078.00	3,489.00	29%	45,500.00	29,933.00	45,500.00	29,933.00
Trash Barrel Liners		14,427.00	13,430.00	997.00	7%	19,954.00	5,527.00	19,954.00	5,527.00
Utilities - Electricity/Gas/Water		195,158.00	183,295.00	11,863.00	6%	206,500.00	11,342.00	206,500.00	11,342.00
Utilities - Telephone		184,159.00	166,043.00	18,116.00	11%	187,169.00	3,010.00	187,169.00	3,010.00
Total Materials/Supplies/Services		<u>9,629,145.00</u>	<u>7,116,263.00</u>	<u>2,512,882.00</u>	35%	<u>12,878,318.00</u>	<u>3,249,173.00</u>	<u>12,878,318.00</u>	<u>3,249,173.00</u>
Tourism Development Specific									
Advertising and Promotions		24,881.00	36,694.00	(11,813.00)	-32%	63,300.00	38,419.00	63,300.00	38,419.00
Advertising - R. A. Apffel		31,293.00	22,576.00	8,717.00	39%	52,000.00	20,707.00	52,000.00	20,707.00
Advertising - Stewart Beach		57,390.00	68,934.00	(11,544.00)	-17%	53,000.00	(4,390.00)	53,000.00	(4,390.00)
Collateral		107,666.00	85,834.00	21,832.00	25%	143,275.00	35,609.00	143,275.00	35,609.00
Floral/Client Amenities		899.00	823.00	76.00	9%	1,500.00	601.00	1,500.00	601.00
Marketing Coop		37,148.00	15,000.00	22,148.00	148%	44,225.00	7,077.00	44,225.00	7,077.00
Marketing Travel		173,248.00	94,143.00	79,105.00	84%	193,186.00	19,938.00	193,186.00	19,938.00
Media Placement		1,776,272.00	1,055,123.00	721,149.00	68%	1,796,800.00	20,528.00	1,796,800.00	20,528.00
Media Production		10,601.00	8,642.00	1,959.00	23%	10,000.00	(601.00)	10,000.00	(601.00)
Photography		12,716.00	7,967.00	4,749.00	60%	10,000.00	(2,716.00)	10,000.00	(2,716.00)
Preplacement		0.00	0.00	0.00	0%	5,000.00	5,000.00	5,000.00	5,000.00
Promotion Materials		114,551.00	63,892.00	50,659.00	79%	100,750.00	(13,801.00)	100,750.00	(13,801.00)
Public Relations		83,108.00	52,228.00	30,880.00	59%	82,500.00	(608.00)	82,500.00	(608.00)
Sales Incentive		236,887.00	62,085.00	174,802.00	282%	263,000.00	26,113.00	263,000.00	26,113.00
Site Tours/Convention Solicitation		57,909.00	32,736.00	25,173.00	77%	74,700.00	16,791.00	74,700.00	16,791.00
Total Tourism Development Specific		<u>2,724,567.00</u>	<u>1,606,677.00</u>	<u>1,117,890.00</u>	70%	<u>2,893,236.00</u>	<u>168,669.00</u>	<u>2,893,236.00</u>	<u>168,669.00</u>

Park Board of Trustees of the City of Galveston  
Consolidated - YTD Statement of Revenues and Expenditures  
From 10/1/2021 Through 9/30/2022

(In Whole Numbers)

	<u>Current Year-To- Date Actual</u>	<u>Prior Year-To-Date Actual</u>	<u>Current Year Change</u>	<u>Current Year % Change</u>	<u>YTD Budget</u>	<u>YTD Budget Variance</u>	<u>Total Budget</u>	<u>Total Budget Variance</u>
Special Projects								
Special Projects	860,051.00	592,142.00	267,909.00	45%	1,047,035.00	186,984.00	1,047,035.00	186,984.00
Unforeseen Special Projects	594,423.00	911,683.00	(317,260.00)	-35%	1,200,000.00	605,577.00	1,200,000.00	605,577.00
Contingency - Board Approval Required	<u>336,293.00</u>	<u>41,232.00</u>	<u>295,061.00</u>	716%	<u>973,959.00</u>	<u>637,666.00</u>	<u>973,959.00</u>	<u>637,666.00</u>
Total Special Projects	<u>1,790,767.00</u>	<u>1,545,057.00</u>	<u>245,710.00</u>	16%	<u>3,220,994.00</u>	<u>1,430,227.00</u>	<u>3,220,994.00</u>	<u>1,430,227.00</u>
Debt Service								
Loans	291,182.00	291,671.00	(489.00)	0%	399,758.00	108,576.00	399,758.00	108,576.00
Capital Leases	<u>164,049.00</u>	<u>283,753.00</u>	<u>(119,704.00)</u>	-42%	<u>252,022.00</u>	<u>87,973.00</u>	<u>252,022.00</u>	<u>87,973.00</u>
Total Debt Service	<u>455,231.00</u>	<u>575,424.00</u>	<u>(120,193.00)</u>	-21%	<u>651,780.00</u>	<u>196,549.00</u>	<u>651,780.00</u>	<u>196,549.00</u>
<b>Total Operating Expenses</b>	<u>24,883,918.00</u>	<u>19,455,315.00</u>	<u>5,428,603.00</u>	28%	<u>30,544,711.00</u>	<u>5,660,792.00</u>	<u>30,544,711.00</u>	<u>5,660,792.00</u>
Capital Assets								
Capital Improvements	9,648.00	101,977.00	(92,329.00)	-91%	900,328.00	890,680.00	900,328.00	890,680.00
Car Counters & Cameras	0.00	0.00	0.00	0%	0.00	0.00	0.00	0.00
Equipment	533,045.00	476,540.00	56,504.00	12%	545,758.00	12,713.00	545,758.00	12,713.00
Gain/Loss on Sale of Equipment	(23,000.00)	(88,981.00)	65,981.00	-74%	0.00	23,000.00	0.00	23,000.00
Landscaping	21,269.00	60,263.00	(38,994.00)	-65%	23,385.00	2,116.00	23,385.00	2,116.00
Leasehold Improvements	0.00	2,302.00	(2,302.00)	-100%	0.00	0.00	0.00	0.00
Total Capital Assets	<u>540,961.00</u>	<u>552,101.00</u>	<u>(11,140.00)</u>	-2%	<u>1,469,471.00</u>	<u>928,510.00</u>	<u>1,469,471.00</u>	<u>928,510.00</u>
Total Expenditures	<u>25,424,880.00</u>	<u>20,007,416.00</u>	<u>5,417,464.00</u>	27%	<u>32,014,182.00</u>	<u>6,589,302.00</u>	<u>32,014,182.00</u>	<u>6,589,302.00</u>
Inter-Fund Transfers	<u>3,656,914.00</u>	<u>2,978,147.00</u>	<u>678,767.00</u>	23%	<u>3,185,470.00</u>	<u>(471,444.00)</u>	<u>3,185,470.00</u>	<u>(471,444.00)</u>
Total Expenditures	<u>29,081,794.00</u>	<u>22,985,563.00</u>	<u>6,096,231.00</u>	27%	<u>35,199,652.00</u>	<u>6,117,858.00</u>	<u>35,199,652.00</u>	<u>6,117,858.00</u>
<b>Net Income</b>	<u>5,898,269.00</u>	<u>6,085,457.00</u>	<u>(187,188.00)</u>	-3%	<u>(3,358,357.00)</u>	<u>9,256,626.00</u>	<u>(3,358,357.00)</u>	<u>9,256,626.00</u>
FEMA								
FEMA Reimbursement	(931,320.00)	(377,190.00)	(554,130.00)	147%	(5,288,219.00)	(4,356,899.00)	(5,288,219.00)	(4,356,899.00)
FEMA Expenditures	24,025.00	112,474.00	(88,449.00)	-79%	5,547,985.00	5,523,960.00	5,547,985.00	5,523,960.00
Total FEMA	<u>(907,295.00)</u>	<u>(264,716.00)</u>	<u>(642,579.00)</u>	243%	<u>259,766.00</u>	<u>1,167,061.00</u>	<u>259,766.00</u>	<u>1,167,061.00</u>
NI - Including FEMA	<u>6,805,564.00</u>	<u>6,350,173.00</u>	<u>455,391.00</u>	7%	<u>(3,618,123.00)</u>	<u>10,423,688.00</u>	<u>(3,618,123.00)</u>	<u>10,423,688.00</u>

Park Board of Trustees of the City of Galveston  
 Consolidated - YTD Statement of Revenues and Expenditures  
 From 10/1/2021 Through 9/30/2022

(In Whole Numbers)

	<u>Current Year-To- Date Actual</u>	<u>Prior Year-To-Date Actual</u>	<u>Current Year Change</u>	<u>Current Year % Change</u>	<u>YTD Budget</u>	<u>YTD Budget Variance</u>	<u>Total Budget</u>	<u>Total Budget Variance</u>
Budget-Use of Reserves	0.00	0.00	0.00	0%	4,258,135.00	(4,258,135.00)	4,258,135.00	(4,258,135.00)
Net Income	6,805,564.00	6,350,173.00	455,391.00	7%	640,012.00	6,165,553.00	640,012.00	6,165,553.00
Depreciation	15,378,233.00	15,055,195.00	323,038.00	2%	0.00	(15,378,233.00)	0.00	(15,378,233.00)
Net Income	(8,572,669.00)	(8,705,022.00)	132,353.00	-2%	640,012.00	(9,212,680.00)	640,012.00	(9,212,680.00)

Park Board of Trustees

Park Admissions

September 30, 2022

	<u>Prior Year</u>		<u>Current Period Change</u>	<u>Current Period Budget</u>	<u>Current Period Budget Variance</u>	<u>YTD Actual</u>	<u>Prior Year</u>		<u>YTD Budget</u>	<u>YTD Budget Variance</u>	<u>Total Budget</u>	<u>Total Budget Variance</u>
	<u>Current Period Actual</u>	<u>Current Period Actual</u>					<u>Actual</u>	<u>Year Change</u>				
<b>Beach User-Restricted</b>												
Dellanera Park-Parking	1,590	3,552	(1,962)	3,107	(1,517)	31,687	35,787	(4,100)	35,890	(4,203)	35,890	(4,203)
R. A. Apffel Park	32,375	52,093	(19,718)	31,740	635	668,530	538,025	130,505	529,000	139,530	529,000	139,530
Stewart Beach Park	57,305	74,521	(17,216)	103,107	(45,802)	602,006	892,852	(290,846)	759,900	(157,894)	759,900	(157,894)
	<b>91,270</b>	<b>130,166</b>	<b>(38,896)</b>	<b>137,954</b>	<b>(46,684)</b>	<b>1,302,223</b>	<b>1,466,664</b>	<b>(164,441)</b>	<b>1,324,790</b>	<b>(22,567)</b>	<b>1,324,790</b>	<b>(22,567)</b>
<b>Variance as Percent</b>			<b>-29.88%</b>		<b>-33.84%</b>			<b>-11.21%</b>		<b>-1.70%</b>		<b>-1.70%</b>
UP/Seawall Parking	145,225	143,898	1,327	178,439	(33,214)	1,882,728	1,771,212	111,516	2,097,269	(214,541)	2,097,269	(214,541)
<b>Variance as Percent</b>			<b>1%</b>		<b>-18.61%</b>			<b>6.30%</b>		<b>-10.23%</b>		<b>-10.23%</b>
<b>Total Beach User</b>	<b>236,495</b>	<b>274,064</b>	<b>(37,569)</b>	<b>316,393</b>	<b>(79,898)</b>	<b>3,184,951</b>	<b>3,237,876</b>	<b>(52,925)</b>	<b>3,422,059</b>	<b>(237,108)</b>	<b>3,422,059</b>	<b>(237,108)</b>
<b>Variance as Percent</b>			<b>-13.71%</b>		<b>-25.25%</b>			<b>-1.63%</b>		<b>-6.93%</b>		<b>-6.93%</b>
<b>Dellanera Park</b>												
Camping - Restricted	23,322	(32,865)	56,187	19,336	3,986	313,130	317,005	(3,875)	264,330	48,800	264,330	48,800
Camping - Unrestricted	55,203	(76,522)	131,726	51,864	3,339	741,179	745,236	(4,057)	625,670	115,509	625,670	115,509
	<b>78,525</b>	<b>(109,387)</b>	<b>187,913</b>	<b>71,200</b>	<b>7,325</b>	<b>1,054,309</b>	<b>1,062,241</b>	<b>(7,932)</b>	<b>890,000</b>	<b>164,309</b>	<b>890,000</b>	<b>164,309</b>
<b>Variance as Percent</b>			<b>-172%</b>		<b>10%</b>			<b>-1%</b>		<b>18%</b>		<b>18%</b>
Seawolf - Gate	36,202	41,704	(5,502)	27,525	8,677	386,856	410,149	(23,294)	344,980	41,876	344,980	41,876
Seawolf - Sub & Ship	18,249	7,898	10,351	1,500	16,749	57,393	35,778	21,615	23,350	34,043	23,350	34,043
Seawolf - Fishing Pier	73,744	77,690	(3,946)	70,000	3,744	736,676	814,067	(77,391)	792,000	(55,324)	792,000	(55,324)
	<b>128,195</b>	<b>127,292</b>	<b>903</b>	<b>99,025</b>	<b>29,170</b>	<b>1,180,925</b>	<b>1,259,994</b>	<b>(79,070)</b>	<b>1,160,330</b>	<b>20,595</b>	<b>1,160,330</b>	<b>20,595</b>
<b>Variance as Percent</b>			<b>1%</b>		<b>29%</b>			<b>-6%</b>		<b>2%</b>		<b>2%</b>
<b>Total Park Admissions</b>	<b>443,215</b>	<b>291,969</b>	<b>151,247</b>	<b>486,618</b>	<b>(43,403)</b>	<b>5,420,185</b>	<b>5,560,111</b>	<b>(139,927)</b>	<b>5,472,389</b>	<b>(52,204)</b>	<b>5,472,389</b>	<b>(52,204)</b>
<b>Variance as Percent</b>			<b>52%</b>		<b>-9%</b>			<b>-3%</b>		<b>-1%</b>		<b>-1%</b>

## Finance & Operations 2022-2023 Workplan

Quarter 1		
<i>October</i>	<i>November</i>	<i>December</i>
No Meeting	Discuss & Consider renewal of credit line at MNB  Discuss & Review Vehicle & Equip. Needs Assessment  Discuss & Review Investment Polciy  Discuss & Review Investment Portfolio Options	No Meeting
Quarter 2		
<i>January</i>	<i>February</i>	<i>March</i>
Receive & Review FY2022 unaudited financial statements Discuss & Review FY2023 financial projections Update on Park Board STR software implementation Discuss & Review City Wage Assessment Survey	Receive & Review FY2020/21 draft financial audit  Discuss & Consider Capital Asset Policy	Discuss & Consider Cash Handling Policy
Quarter 3		
<i>April</i>	<i>May</i>	<i>June</i>
Discuss & Review FY2023 financial projections  Discuss & Consider Accounts Payable and Credit Card Use Policies	No Meeting	Discuss & Recommend FY2024 HOT values
Quarter 4		
<i>July</i>	<i>August</i>	<i>September</i>
Discuss & Review 2024 draft park budgets Discuss & Review 2024-2028 Capital Improvement Plans Discuss & Review FY2023 financial projections	Discuss & Recommend merit increase Discuss & Recommend compensation changes Discuss & Review 2024 draft gov. fund budgets	Discuss & Consider FY2024 full budget

**On-going agenda items:**

- Receive and review monthly financial statements
- Receive and review quarterly financial reports
- New Concessionaire Agreements